

**LOS ALAMITOS COUNTY  
WATER DISTRICT  
ORANGE COUNTY, CALIFORNIA**

**STANDARD SPECIFICATIONS FOR  
THE CONSTRUCTION OF  
SANITARY SEWERS**

NOVEMBER 1980



***Boyle Engineering Corporation***

*consulting engineers / architects*

M A S T E R

T A B L E   O F   C O N T E N T S

PART I - GENERAL CONDITIONS

PART II - MATERIALS OF CONSTRUCTION

PART III - METHODS OF CONSTRUCTION

STANDARD DETAIL DRAWINGS

I N D E X

PART 1 - GENERAL CONDITIONS

	<u>PAGE</u>
SECTION 1 - SEWER DESIGN CRITERIA AND PLAN CHECKING	1
1-1 General	1
1-2 Design Criteria	1
1-2.1 New Subdivisions	1
1-2.1.1 Existing Developments	1
1-2.1.2 Authorization	1
1-3 Plan Checking	2
1-3.1 Preparation	2
1-3.2 Preliminary Engineering Fees	2
1-3.3 Authorization	2
1-3.4 Final Engineering and Inspection Fees	2
1-3.5 District Engineer's Copies of the Plans	2
1-3.6 Easements	3
1-3.7 Start of Construction	3
SECTION 2 - SEWER CONSTRUCTION AND INSPECTION	1
2-1 Governing Specifications	1
2-2 Schedule	1
2-3 Notice	1
2-4 Permits	1
2-5 Inspection	1
2-6 Indemnity Bond	2
2-7 Bond Release	2
SECTION 3 - DEFINITIONS AND TERMS	1
3-1 General	1
3-1.1 A.S.T.M.	1
3-1.2 Board of Directors or Board	1
3-1.3 Construction Schedule	1
3-1.4 Contractor	1
3-1.5 District	1
3-1.6 Engineer	1
3-1.7 Final Acceptance	1
3-1.8 General Manager	2
3-1.9 Laboratory	2
3-1.10 Owner	2

PART 1 - GENERAL CONDITIONS INDEX - Continued

	<u>PAGE</u>
3-1.11 Plans	2
3-1.12 Specifications	2
3-1.13 State Specifications	2
3-1.14 Surety or Sureties	2
3-1.15 Terms	2
3-1.16 Trade Names	3
3-1.17 Work	3
3-1.18 Lot	3
3-1.19 Building	3
3-1.20 Fixture	3
3-1.21 Main Sewer	3
3-1.22 Connecting Sewer	4
3-1.23 House Sewer	4
3-2 Standard Specifications	4
3-3 Interpretation of Specifications and Detail Drawings	4
3-4 Material and Equipment Drawings	5
3-5 Conformity with Plans and Allowable Deviation	5
3-6 Construction Water	5
3-7 Connecting to Existing District Facilities	5
3-8 No Personal Liability	5
3-9 Responsibility for Damage	5
3-10 Legal Relations and Responsibility	6
SECTION 4 - GENERAL RULES AND REGULATIONS	1
4-1 Connection Permit	1
4-2 Connection Requirements	1
4-3 Bonds and Deposits	2

PART I  
GENERAL CONDITIONS

SECTION 1.

SEWER DESIGN CRITERIA AND PLAN CHECKING

1-1                    General

The following is the procedure for an owner, developer or engineer for an owner or developer, to follow in getting sewer plans approved in Los Alamitos County Water District of Orange County, California.

1-2                    Design Criteria

1-2.1                New Subdivisions

The developer or engineer for the developer upon final approval of the tentative tract map by the County Planning Commission, shall request, in writing, from the District Engineer that the sewer design criteria for his respective tract be established. If an offsite sewer trunk is to be built to a District trunk, design criteria for this facility shall also be requested.

1-2.1.1            Existing Development

In those cases where sewers are contemplated by owner(s) of property which are not new subdivisions, such as, off-site sewers for existing dry sewer areas or proposed sewers which are to be privately financed and built in public streets and easements, the owner(s) or the owner(s) engineer shall request, in writing, from the District Engineer that the design criteria for the proposed sewer improvements be established.

1-2.1.2            Authorization

After receiving a request for design criteria, the District Engineer shall establish the base design criteria required. Said criteria will be given to the owner(s) or developer's engineer for preparation of improvement plans for the installation of sanitary sewers.

1-3

Plan Checking

1-3.1

Preparation

All sewer plans must be prepared under the direct supervision of a registered Civil Engineer licensed to practice in the State of California. This requirement must be attested to by the engineer's signature on the plans.

1-3.2

Preliminary Engineering Fees

Upon completion of the improvement plans, the engineer will submit them to the District Engineer for plan checking at which time a deposit shall be made with the District, equal to Eight Dollars (\$8.00) per lot. In the event the sewer is either an offsite sewer or a sewer for areas not being subdivided, the preliminary engineering fee shall be four percent (4%) of the District Engineer's construction cost estimate.

1-3.3

Authorization

Upon receipt of the deposit by the District office the District Engineer will proceed with the plan checking.

1-3.4

Final Engineering and Inspection Fees

Following the completion of the final checking of the improvement plans, the developer's engineer, or the developer, will be advised to deposit with the District six percent (6%) of the District Engineer's construction cost estimate. The plan checking fee of the initial deposit will be credited toward this six percent (6%). Upon receipt of notification that such deposit has been received by the District and upon being presented with plans prepared in conformance with the District's requirements, the District Engineer will approve the sewer design on behalf of the District.

1-3.5

District Engineer's Copies of the Plans

Upon approval of the plans, the District's Engineer shall be furnished three (3) complete sets of prints of the plans.

1-3.6

Easements

In case an easement is required for construction and/or maintenance of sanitary sewers, the minimum width shall be fifteen feet (15') unless otherwise determined by the District Engineer. Easement descriptions and accompanying plats shall be prepared by the owner's engineer. The easement shall be in a form acceptable to the District and will be checked by the District Engineer. Easements shall be shown on the sewer plans. The District will not approve any sewer plans until all required easements have been irrevocably offered for dedication to the District.

1-3.7

Start of Construction

No work may start until the required approved plans have been filed with the District Engineer.

## SECTION 2

### SEWER CONSTRUCTION AND INSPECTION

#### 2-1 Governing Specifications

All construction shall be in accordance with the Standard Specifications of the District.

#### 2-2 Schedule

The Contractor shall submit a schedule to the District Engineer outlining his proposed construction operation. Whenever the Contractor varies the period during which work is carried on each day, he shall give due notice to the District Engineer so that proper inspection may be provided. Any work done in the absence of the District Inspector will be subject to rejection.

#### 2-3 Notice

Notice shall be given to the District Engineer at least two (2) working days in advance of commencement of work.

#### 2-4 Permits

The owner(s) developer or their contractor shall secure all excavation permits and all licenses required for the work. These shall be recorded with the District prior to commencement of work.

#### 2-5 Inspection

All work shall be subject to inspection by the District and shall be left open and uncovered until the installation is approved by appropriate District authority.

The Contractor shall not proceed with any subsequent phase of work until the previous phase has been inspected and approved by the District. Inspection shall be made at the following intervals of work:

- (a) Trench Excavation and Bedding
- (b) Placing of Pipe, Fittings and Structures.
- (c) Backfill (Performed by Orange County Highway Department)
- (d) Testing
- (e) Placing in Service



The District shall at all times have access to the work during construction and shall be furnished with every reasonable facility for ascertaining full knowledge respecting the progress, workmanship, and character of materials used and employed in the work.

No pipe, fittings, or other materials shall be installed until inspected and approved by the District or its representative. All installations which are to be backfilled shall be inspected and approved by the District prior to backfilling, and the Contractor shall give due notice in advance of backfilling to the District Engineer so that proper inspection may be provided.

The inspection of the work shall not relieve the Contractor of any of his obligations to complete the work as prescribed by the Standard Specifications. Defective work shall be made good, and unsuitable materials may be rejected notwithstanding the fact that such defective work and unsuitable materials have been previously overlooked by the District and accepted.

The District shall have the authority to suspend the work wholly or in part for such time as it may deem necessary due to the failure on the part of the Contractor to carry out orders given, or to perform any provisions of the Plans or Specifications. The Contractor shall immediately comply with the written order of the District to suspend the work wholly or in part. The work shall be resumed when methods or defective work are corrected as ordered or approved in writing by the District.

2-6

#### Indemnity Bond

If sewer facilities are to be constructed in a right of way under the jurisdiction of an agency requiring the District to sign the application for the encroachment permit, the applicant shall furnish the District with an indemnity bond prior to execution of the application.

2-7

#### Bond Release

Following the satisfactory completion of the construction of the sewer improvements, the District Engineer will write a letter to the District recommending acceptance of the sewers; and the District, in turn, will advise the County Surveyor's office that said sewers have been constructed and inspected in accordance with the Plans and Specifications and that the bonds furnished by the developer in connection therewith can be released.

## SECTION 3

### DEFINITIONS AND TERMS

#### 3-1 General

The following words or abbreviations as used in these Specifications, are respectively as follows:

##### 3-1.1 A.S.T.M.

The American Society for Testing Materials. All references to the specifications of the A.S.T.M. are understood to refer to the current specifications as revised or amended at the date of construction.

##### 3-1.2 Board of Directors or Board

The Board of Directors of Los Alamitos County Water District of Orange County, California.

##### 3-1.3 Construction Schedule

The Contractor's written estimate in detail as required by the District, showing the estimated dates that certain portions of the work will be started and completed and the rate of prosecution of individual portions of the work as planned by the Contractor.

##### 3-1.4 Contractor

The persons, firm, or corporation entering into Contract with the owner, for the performance of the work required under said Contract, the District ordinances and these Specifications.

##### 3-1.5 District

Los Alamitos County Water District of Orange County, California, its authorized employees, and agents.

##### 3-1.6 Engineer

The Engineer designated by the District, acting either directly or through properly authorized agents.

##### 3-1.7 Final Acceptance

The formal action by the District accepting the work as fully completed after certification of full completion by the Engineer and approval of the Board.

3-1.8 General Manager

An individual designated by the District as its chief executive officer and agent for the District.

3-1.9 Laboratory

The materials testing laboratory authorized by the District to test materials and work involved in the construction of the sanitary sewers.

3-1.10 Owner

The applicant or owner requesting the installation or construction of sanitary sewers for integration with the collecting sewer system of Los Alamitos County Water District and County Sanitation District No. 3.

3-1.11 Plans

That part of the Plans and Specifications which consist of the plans, profiles, typical cross-sections, general cross-sections and working drawings, or exact reproductions thereof, which show the location, character, dimensions and details of the work to be done.

3-1.12 Specifications

The directions, provisions, and requirements of the District pertaining to the method and manner of performing the work and to the qualities and quantities of materials to be furnished for the work.

3-1.13 State Specifications

The Standard Specifications, State of California, Department of Public Works, Division of Highways, as published January, 1960.

3-1.14 Surety or Sureties

The bondsmen or party or parties who may guarantee the fulfillment of the work, or a portion of the work by bond, and whose signatures are attached to the bond.

3-1.15 Terms

The terms "Approved," "Directed," "Satisfactory," "Accepted," "Acceptable," "Proper," "Required," "Necessary," and "or Equal," mean as approved, directed, satisfactory, accepted, acceptable, proper, required, necessary, or equal, in the opinion of the Engineer.

3-1.16

Trade Names

Where a certain product is called for by name, it is intended as a guide for type and quality. Other products which the Contractor desires to use in place of those specified must be, in the opinion of the Engineer, of equal type and quality. A Contractor's desire to use an alternate product must be made in writing to the Engineer thirty (30) days prior to starting construction.

3-1.17

Work

All the work specified in the Standard Specifications and Plans necessary to complete the construction of sanitary sewers.

3-2

Standard Specifications

District Resolution No.        under which these Specifications are adopted, is hereby made a part of these Specifications by reference, and all provisions of said Resolution shall be complied with by the Contractor.

3-3

Interpretation of Specifications and Detail Drawings

Figured dimensions of the Drawings shall govern, but work not dimensioned shall be as directed. Work not particularly shown or specified shall be the same as similar parts which are shown or specified, or as directed. Full-size details shall take precedence over scale drawings as to shape and details of construction. Specifications shall govern as to material.

Scale Drawings, full-size details, and Specifications are intended to be fully cooperative and to agree, but should any discrepancy or apparent difference occur between Plans and Specifications, or should error occur in the works of others affecting the work, the Contractor shall notify the District at once. If the Contractor proceeds with the work affected without instructions from the District, he shall be fully responsible for any resultant damage or defect.

3-4

Material and Equipment Drawings

Fabricated materials or equipment to be incorporated in the work shall be approved by the Engineer. The Contractor shall obtain and check manufacturer's shop drawings and other pertinent data for conformance with all requirements of the Drawings and Specifications. After completion of such checking and verification, the Contractor shall submit the shop drawings and pertinent data to the Engineer for approval. It shall be in such detail as the Engineer may require for information as to the design, installation and operation of such items, and their compliance with the Plans and Specifications. The Engineer shall have ten (10) days from date of receipt of such shop drawings to approve or reject the same.

3-5

Conformity with Plans and Allowable Deviation

Finished surfaces in all cases shall conform with the lines, grades, cross-sections, and dimensions shown on the approved Plans. Deviations from the approved Plans, as may be required by the exigencies of construction will be determined in all cases by the Engineer and authorized in writing.

3-6

Construction Water

Water used for construction and testing shall be arranged for and furnished by the Contractor at his expense.

3-7

Connecting to Existing District Facilities

The Contractor may not make a connection to existing District facilities or interrupt sanitary sewer service in any portion of the District until the proper procedures have been followed and the District has approved and scheduled said connection.

3-8

No Personal Liability

Neither the Board of Directors, the Engineer, nor any other officer or authorized assistant or agent of the District shall be personally responsible for any liability arising out of the work performed.

3-9

Responsibility for Damage

The District, the Board of Directors, or the Engineer shall not be answerable or accountable in any manner for any loss or damage that may happen to the work or any part thereof; or for any material or equipment used in performing the work; or for injury or damage to any person or persons, either workmen or the public; or for damage to adjoining property from any cause whatsoever during the progress of the work or at any time before final acceptance.

Legal Relations and Responsibility

The Contractor shall keep himself fully informed of all laws, ordinances, and regulations which in any manner affect those engaged or employed in the work, or the materials used in the work, or which in any way affect the conduct of the work, and of all such orders and decrees of bodies or tribunals having any jurisdiction or authority over the same. If any discrepancy or inconsistency is discovered in the Plans, Drawings, Specifications, or other documents in relation to any such law, ordinance, regulation, order or decree, the Contractor shall forthwith report the same to the District in writing. The Contractor shall at the time observe and comply with and shall cause all of his agents and employees to observe and comply with all such existing and future laws, ordinances, resolutions, regulations, orders and decrees, and shall protect and indemnify the District, the Board of Directors, the Engineer, and all of its and their officers and agents, against any claim or liability arising from or based on the violation of any such law, ordinance, regulation, order or decree, whether by himself or his employees.

## SECTION 4

### GENERAL RULES AND REGULATIONS

4-1

#### Connection Permit

It shall be unlawful for any person, firm, or corporation to make or attempt to make or cause to be made any connection with the main sewer lines of Los Alamitos County Water District of Orange County, California, without first having secured a permit therefor and having paid an application fee of Three Dollars (\$3.00). A permit to make such connection shall be granted upon application made upon blank forms furnished by the District and in the manner as in said form prescribes, which application shall be filed with the secretary of said District together with the application fee of Three Dollars (\$3.00); and the secretary shall thereupon be authorized to issue a permit for making such connection. In the absence of the secretary, the application shall be referred to an authorized agent of Los Alamitos County Water District of Orange County, California, who shall be authorized to issue a permit for making such connection. The fee so paid shall be deposited in the treasury of said District. All sewer connections and pipe lines laid in connection therewith must be under the supervision of the inspection of said District and in conformity with the requirements and provisions relating to such connection prescribed by the Board of said District.

4-2

#### Connection Requirements

All sewer connection lines shall be placed at a minimum depth of five feet (5') below the top of the curb for that portion of the line in the street, and where there are no curbs or established grade at the top of the pipe, shall be a minimum of five feet (5') below the ground surface. Every building or other structure situated within Los Alamitos County Water District of Orange County, California, shall be separately and independently connected with a connecting sewer except where more than one building or other structure is situated upon the same lot in which case all such buildings or structures may by a special permit be authorized by the Board of said District to be joined in the use of one house and connecting sewer provided upon, however, that all such buildings or structures are owned by the same person, firm, or corporation. Connecting sewers may be constructed of 4-inch V.C.P. provided the number of fixture units served is not over thirty-six (36); if the number of fixture units exceed thirty-six (36), the size of the pipe for each connecting sewer shall be six inches (6") or larger. All wye and tee openings in sewers

which are not used for connections shall be closed by the use of water-tight caps. No steam exhaust shall be connected to any sewer. The steam exhaust, however, may be connected to a steam condenser and the condenser pipe from such steam condenser may be connected to the sewer system provided the temperature of the water discharge is less than 140° F.

4-3

#### Bonds and Deposits

To insure the District and the County of Orange that construction of sewers will be completed in accordance with the plans as approved by the District and within the time as provided by the County of Orange, a bond or cash shall be furnished by the subdivider, or land developer, and deposited with the County Surveyor of Orange County prior to the approval of the plans by the District guaranteeing the faithful performance of all the work in a sum equal to the estimated cost. The deposit required to be made may be made either by cash or by cashier's check and in all events the same must be in the hands of the Secretary of the District prior to the approval of the sewer plans by the District. All the sums of money deposited or required to be deposited by the District as provided shall become the property of the District and no part thereof shall be refunded or refundable by the District to the developer or subdivider.



## INDEX

### PART II - MATERIALS OF CONSTRUCTION

	<u>PAGE</u>
SECTION 10 - CONTROL OF MATERIALS	1
10-1 Samples and Tests	1
10-2 Defective Materials	1
SECTION 11 - VITRIFIED CLAY PIPE	1
11-1 Quality of Pipe	1
11-1.1 General	1
11-1.2 Identification Marks	1
11-1.3 Tests	1
11-1.3.1 Hydrostatic Test	2
11-1.3.2 Loading Test	2
11-1.3.3 Acceptance or Rejection as Result of Test	3
11-1.4 Inspection Independent of Tests	3
11-1.4.1 Cracked Pipe	3
11-1.4.2 Surface Imperfections	3
11-1.4.3 Socket Out-of-Round	3
11-1.4.4 Straight Pipe	3
11-1.4.5 Broken Pipe	3
11-1.4.6 Foreign Matter Fused to Pipe	3
11-2 Vitrified Clay Pipe Joints	4
11-2.1 Other Types of Joints	4
11-3 Branches	4
11-4 Stoppers	4
11-5 V.C.P. Bedding	5
SECTION 12 - PLASTIC SEWER PIPE	1
12-1 General	1
12-2 PVC Pipe	1
12-2.1 Identification Marks	1
12-2.2 Cell Classification	2
12-2.3 Joining Systems	2
12-2.4 Test Requirements	2
12-2.5 Gaskets for PVC Pipe	3
12-3 ABS Solid Wall Pipe	4
12-3.1 Material Composition and Testing	4
12-3.2 Pipe Acceptance	5

PART II - MATERIALS OF CONSTRUCTION INDEX - Continued

	<u>PAGE</u>
SECTION 12 - PLASTIC SEWER PIPE (Continued)	
12-3.3    Marking	6
12-3.4    Repair	6
12-4      ABS Composite Pipe	6
12-4.1  Material Composition and Testing	6
12-4.2  Pipe Acceptance	6
12-5      Bedding	7
SECTION 13 - PORTLAND CEMENT CONCRETE	1
13-1      General and Classes	1
13-2      Cement	1
13-3      Portland Cement Concrete	1
13-4      Reinforcing	1
SECTION 14 - PRECAST REINFORCED PORTLAND CEMENT CONCRETE MANHOLES	1
14-1      General	1
14-2      Fabrication	1
SECTION 15 - MANHOLE FRAMES AND COVERS	1
15-1      General	1
SECTION 16 - STEEL CASING PIPE	1
16-1      General	1
SECTION 17 - EPOXY RESIN	1
17-1      General	1

PART II

MATERIALS OF CONSTRUCTION

SECTION 10

CONTROL OF MATERIALS

10-1           Samples and Tests

At the option of the Engineer the source of supply of each of the materials shall be approved by him before the delivery is started and before such material is used in the work.

All tests of materials furnished by the Contractor shall be made in accordance with the commonly recognized standards of national technical organizations, and such special methods and tests as are prescribed in these Specifications.

The Contractor shall furnish the District in triplicate, certified copies of all requested factory and mill test reports. Any materials shipped by the Contractor from a factory or mill prior to having satisfactorily passed such testing and inspection by a representative of the District shall not be incorporated in the work, unless the Engineer has notified the Contractor in writing that such testing and inspection will not be required.

The Contractor shall furnish and deliver to the laboratory such samples of materials as are requested by the Engineer, without charge. No material shall be used until it has been approved by the Engineer. Samples will be secured and tested whenever necessary to determine the quality of the material. All testing expenses are to be paid by the Contractor.

10-2           Defective Materials

All materials not conforming to these Specifications shall be considered defective, and all such materials, whether in place or not, shall be rejected and shall be removed immediately from the site of the work unless otherwise permitted by the Engineer. No rejected material, the defects of which have been subsequently corrected, shall be used until approved in writing by the Engineer.

## SECTION 11

### VITRIFIED CLAY PIPE

#### 11-1 QUALITY OF PIPE

- 11-1.1 General - All vitrified clay pipe (V.C.P.) and fittings shall be of one class; designated extra strength; of the best quality; vitrified; homogenous in structure; thoroughly burned throughout their entire thickness; impervious to moisture; sound; and free from cracks, checks, blisters, broken extremities, or other imperfections; and must give a metallic ring when struck with a hammer. Pipe shall be bell and spigot pipe, unless otherwise specified. Pipe ends shall be square with the longitudinal axis, and sockets shall be true, circular, and concentric with the barrel of the pipe. The thickness of the shell, the depth of the socket, and the dimension of the annular space shall be within the limits of permissible variation to dimension standards of the specifications of the Clay Pipe Institute, 2600 Wilshire Boulevard, Los Angeles, California 90057, and to the applicable provisions of ASTM C 700, for the size of pipe indicated on the plans. All pipe and special fittings shall comply with the provisions of ASTM C 700 with respect to the hydrostatic pressure test, size, shape, 3-edge bearing load test, and all other requirements of said provisions.
- 11-1.2 Identification Marks - All pipe or fittings shall be clearly marked with the name of the manufacturer or with a trademark of a size and type that has been approved by the District Engineer or Inspector.
- 11-1.3 Tests - Before being used in any work under these specifications, pipe shall be subjected to and shall meet the requirements of the following hydrostatic pressure test and loading test; these tests shall be made by the Contractor and shall be witnessed by a reputable testing laboratory. The Contractor shall deliver the pipe selected for testing to the place and at the time designated by the testing laboratory. All costs of furnishing, transporting, and handling the pipe for testing and conducting the tests shall be borne by the Contractor.
- In lieu of witnessing by a testing laboratory, the Contractor may furnish a certified statement from the pipe manufacturer stating that all prescribed tests have been made and pipe to be used on the project has met all requirements of the specifications.
- The testing laboratory shall select, at random, for testing as herein specified, no less than 1% of the number of pipe in each size of pipe furnished.

The specimens selected for testing shall be sound pipe having dimensions consistent with these specifications. The lot or lots from which the test samples are taken shall be sufficient to fill the entire order for that size of pipe used in the work under the contract and, if they pass the tests, shall be so designated and marked.

All pipe shall be subject to inspection at the factory, trench, or other point of delivery by the District Engineer. The purpose of the inspection shall be to cull and reject any pipe that, independent of the physical tests herein specified, fails to conform to the requirements of these specifications or that may have been damaged during transportation or in subsequent handling.

11-1.3.1

Hydrostatic Test - In lieu of the standard ASTM absorption test, the following hydrostatic pressure test shall be substituted. The hydrostatic pressure test shall precede the loading test by not less than one hour or more than three hours and shall be applied to all the specimens received for test in each size of pipe.

When subjected to an internal hydrostatic pressure of 10 psi for the time specified hereafter, the accumulated moisture on the exterior surface of the pipe shall not run down the sides in such quantity that it will exceed 10 ml.

<u>Thickness of Barrel</u>	<u>Minimum Testing Time (minutes)</u>
Up to and including 1 inch	7
Over 1 inch and including 1-1/2 inches	9
Over 1-1/2 inches and including 2 inches	12
Over 2 inches and including 2-1/2 inches	15
Over 2-1/2 inches and including 3 inches	18
Over 3 inches	21

11-1.3.2

Loading Test - The loading test shall be the 3-edge bearing test. The loading tests shall conform to the applicable provisions of ASTM C 301 and shall be applied to all specimens selected for testing, except that loading to test ultimate strength will not be required. Pipe shall withstand the following loads:

<u>Nominal Pipe Size (inches)</u>	<u>Minimum Test Loads (pounds per linear foot)</u>
4 and 6	2,000
8	2,200
10	2,400
12	2,600

The net inside length of the pipe from the bottom of the socket to spigot end of the pipe shall be used as the divisor to calculate the load per linear foot.

11-1.3.3 Acceptance or Rejection as Result of Test - If all of the minimum designated percentage or number of the specimens tested meet the requirements of the test, then all of the pipe in the lot, shipment, or delivery corresponding to the sizes and classes so tested shall be considered as complying with the test. If, however, 10% or more of the specimens tested fail to meet the requirements of the test or if more than one specimen fails to meet the requirements of the test when the number to be tested is less than ten, then a second selection of pipe shall be made for that test. The number of specimens to be tested in the second selection of pipe shall be five for each specimen of the first selection that failed to meet the requirements.

If 90% or more of the specimens tested, including those first tested, meet the requirements of the test, all the pipe in the lot, shipment, or delivery corresponding to the sizes and classes so tested shall be considered as complying with that test; otherwise all pipe of these sizes and classes shall be rejected.

11-1.4 Inspection Independent of Tests - The following imperfections in a pipe or special fitting will be considered injurious and cause for rejection without consideration of the test results specified above.

11-1.4.1 Cracked Pipe - A single crack in the barrel of the pipe will cause rejection.

11-1.4.2 Surface Imperfections - Surface imperfections, such as lumps, blisters, pits, or flakes, on the interior surface of a pipe or fitting will cause rejection.

11-1.4.3 Socket Out-of-Round - When the bore or socket of the pipe varies from a true circle more than 3% of its nominal diameter, the pipe will be rejected.

11-1.4.4 Straight Pipe - The pipe or fitting will be rejected if it is designated to be straight and it deviates from a straight line more than 1/16 inch per linear foot. The deviation shall be measured from a straight edge at a point midway between the ends of the pipe.

11-1.4.5 Broken Pipe - A joint of pipe with a piece broken from either the socket or spigot end will be rejected.

11-1.4.6 Foreign Matter Fused to Pipe - Pipe joints that have tramp clays, grog, or other foreign matter fused permanently to the exterior or interior surface of the pipe or fittings will be rejected.

11-2 Vitrified Clay Pipe Joints - All V.C.P. and fittings shall be furnished with compression joints equal to "Wedge-Lock" manufactured by Pacific Clay Products or "Speed Seal" manufactured by Pacific Coast Building Products. The compression joint on the spigot and bell ends of the pipe shall be factory made of plastisol or other approved resilient element bonded onto the outside of the spigot and the inside of the bell to the pipe and molded and cured to a uniform hardness and compressibility to form a tight compression coupling when assembled. Materials for compression joints shall conform to ASTM C 425.

11-2.1 Other Types of Joints - Where pipe from different manufacturers is to be jointed together, an adapter pipe with the proper matching joint on each end for the respective manufacturer shall be used. Hot poured joints or concrete encasement of plain end joints will not be permitted.

11-3 Branches - Branches of the type shown on the plans shall be furnished with connections of the sizes specified and shall be securely and completely fastened to the barrel of the pipe in the process of manufacture. This shall be accomplished by fusion during vitrification. In the case of pipe 15 inches or greater in diameter, fusion during vitrification will not be required, but if not fused, in addition to other fastening material of approved quality, there shall be a reinforcing collar of portland cement mortar around the outside of the joint and there shall be no exposure of portland cement mortar on the interior surface of the pipe. Tee branches shall have their axis perpendicular to the longitudinal axis of the pipe. Wye branches shall have their axis approximately 45 degrees (unless otherwise specified on the plans) to the longitudinal axis of the pipe, measured from the socket end. All branches shall terminate in sockets and the barrel of the branch shall be of sufficient length to permit making a proper joint when the connecting pipe is inserted in the branch socket.

The quality of V.C.P. branches shall conform to the applicable provisions of V.C.P. as specified herein.

11-4 Stoppers - Vitrified clay stoppers shall be 3/4-inch thick and shall have a factory-made plasticized PVC compound joint material cast and bonded to the pipe equal to Wedge-Lock or Speed Seal. The material shall be molded and cured to a uniform hardness and compressibility and form a tight compression coupling when assembled. The material used for the compression joint shall conform to ASTM C 425.

Neoprene (synthetic rubber) stoppers shall be equal to those manufactured by Pacific Clay Products or Pacific Coast Building Products. The joint formed by the stopper and clay pipe shall be a tight compression coupling when assembled.

All joints for stoppers shall be adequate to withstand the internal pressure of the leakage and infiltration test; however, joints shall be made so they may be removed without injury to the socket.

11-5

V.C.P. Bedding - Minimum bedding of V.C.P. shall be as shown on Standard Drawing S-5.

Crushed rock shall be the product of crushing rock or gravel. Fifty percent of the particles retained on a 3/8-inch sieve shall have their entire surface area composed of faces resulting from fracture due to mechanical crushing. Not over 5% shall be particles that show no faces resulting from crushing. Less than 10% of the particles that pass the 3/8-inch sieve and are retained on the No. 4 sieve shall be waterworn particles. Gravel shall not be added to crushed rock.

Gravel shall be defined as particles that show no evidence of mechanical crushing, are fully waterworn, and are rounded. For pipe bedding, where gravel is specified, crushed rock may be substituted or added.

Where crushed rock or gravel is specified in the bedding details, the material shall have the following gradations:

<u>Sieve Size</u>	<u>1-1/2-Inch- Max-Gravel % Passing</u>	<u>1-Inch- Max-Gravel % Passing</u>	<u>3/4-Inch- Max-Crushed Rock % Passing</u>
2"	100	-	-
1-1/2"	90-100	100	-
1"	20-55	90-100	100
3/4"	0-15	60-80	90-100
1/2"	-	-	30-60
3/8"	0-5	0-15	0-20
No. 4	-	0-5	0-5
No. 8	-	-	-

Unless otherwise specified, 3/4-inch-maximum crushed rock shall be used for pipes with inside diameters of 30 inches and less.



## SECTION 12

### PLASTIC SEWER PIPE

12-1 General - Unplasticized PVC or acrylonitrile-butadiene-styrene (ABS) solid wall or ABS composite wall plastic pipe may be used on a case-by-case basis as an alternate to V.C.P. on residential tract sewers and residential house laterals only to sizes not exceeding 10 inches in diameter. The District shall determine the suitability of plastic sewer pipe for residential use on a case-by-case basis. Plastic sewer pipe will not be used without being clearly indicated on the approved plans.

Use of PVC or ABS for main line sewers on industrial, commercial, and medical installations will not be permitted. If the option of installing PVC or ABS pipe is exercised, such option shall apply to a minimum reach of the sewer between any two manholes and shall include the house laterals in that reach. Except as modified herein, the design criteria and requirements for PVC and ABS pipe shall be the same as used for V.C.P.

The maximum design deflection for plastic sewer pipe shall be 3%.

Pulling of joints or beveling pipe ends to achieve curvature will not be permitted. Bending of PVC or ABS solid wall pipe to achieve vertical or horizontal curves without using deflection fittings shall be limited as follows:

<u>Nominal Pipe Diameter</u> <u>(inches)</u>	<u>Minimum Radius</u> <u>(feet)</u>
6	210
8	280
10	350
12	420

Curves of radii less than shown above can be achieved with 5-degree deflection fittings.

12-2 PVC Pipe - Unplasticized PVC pipe, fitting, couplings, and joints shall conform to the requirements of ASTM D 3034, SDR 35, and shall have gasketed joints.

12-2.1 Identification Marks - All pipe, fittings, and couplings shall be clearly marked at an interval not to exceed 5 feet as follows:

- (1) Nominal pipe diameter.
- (2) PVC cell classification.
- (3) Company, plant, shift, ASTM, Standard Dimension Ratio (SDR), and date designation.
- (4) Service designation or legend.

For fittings and couplings, the SDR designation is not required.

12-2.2 Cell Classification - Pipe shall be made of PVC having a cell classification of 12454-B, 13364-A, or 13364-B as defined in ASTM D 1784. The fittings shall be made of PVC having a cell classification of 12454-B, 12454-C, or 13343-C.

12-2.3 Joining Systems - All pipe shall have a home mark on the spigot end to indicate proper penetration when the joint is made.

The socket and spigot configurations for the fittings and couplings shall be compatible to those used for the pipe.

Pipe shall be joined with elastomeric gasketed joints manufactured with a socket configuration which will forestall improper installation of the gasket and will ensure the gasket remains in place during the joining operation.

The gasket shall be manufactured from a synthetic elastomer conforming to the requirements of Subsection C-2.5 and factory installed in the belled end of the pipe.

12-2.4 Test Requirements - Pipe, fittings, and couplings shall meet the requirements of the section titled "Requirements" of ASTM D 3034. During production of the pipe, the manufacturer shall perform the specified tests for each pipe marking. A certification by the manufacturer indicating compliance with specification requirements shall be delivered with the pipe. The certification shall include the test result data.

The basis for acceptance shall be the inspection of pipe, fittings, and couplings; the tests specified above; and compliance with the specifications. When the pipe is delivered to the jobsite, the District Engineer may require additional testing to determine conformance with the requirements of pipe flattening, impact resistance, pipe stiffness, and extrusion quality. Also pipe which is not installed within 120 days of the latest test shall not be used without prior approval of the District Engineer.

When testing is required by the District Engineer, one test pipe shall be selected at random by the District Engineer from each 1,200 feet or fraction thereof of each size of pipe delivered to the jobsite but no less than one test pipe per lot. A lot shall be defined as pipe having the same identification marking. The length of specimen for each selected pipe shall be a minimum of 8 feet.

12-2.5

Gaskets for PVC Pipe - Unless otherwise specified, gaskets shall be manufactured from a synthetic elastomer. The compound shall contain not less than 50% by volume of first-grade synthetic rubber. The remainder of the compound shall consist of pulverized fillers free of rubber substitutes, reclaimed rubber, and deleterious substances.

Gaskets shall be extruded or molded and cured in such a manner as to be dense, homogenous and of smooth surface, free of pitting, blisters, porosity, and other imperfections. The tolerance for any diameter measured at any cross section shall be  $\pm 1/32$  inch.

When required by the District Engineer, the Contractor shall furnish test samples of gaskets from each batch used in the work. Gasket material shall meet the following property requirements:

<u>Property</u>	<u>Value</u>	<u>ASTM Test Method</u>
Tensile strength (min. psi)	2,000	D 412
Elongation at break (% min.)	350	D 412
Shore durometer, Type A (Pipe manufacturer shall select value suitable for type of joint)	40 to 65*	D 2240
Compression set (constant deflection) max. % of original deflection	16	D 395 Method B
Tensile strength after oven aging (96 hours, 158° F [70° C]) % of tensile strength before aging	80	D 573

---

\* This applies only to the sealing component of the gasket.

Increase in Shore durometer hardness after oven aging. Maximum increase over original Shore durometer 10 D 2240

Physical requirements after exposure to ozone concentration (150 pphm. 70 hours, 140° F [40° C], 20% strain) No Cracks D 1149

No more than one splice will be permitted in a gasket. A splice shall be made by applying a suitable cement to the ends and vulcanizing the splice in a full mold. The splice shall show no separation when subjected to the following tests:

- (1) Elongation Test. The part of the gasket which includes the splice shall withstand 100% elongation with no visible separation of the splice. While in the stretched position, the gasket shall be rotated in the spliced area minimum of 180 degrees in each direction in order to inspect for separation.
- (2) Bend Test. The portion of the unstretched gasket containing the splice shall be wrapped a minimum of 180 degrees and a maximum of 270 degrees around a rod of a diameter equal to the cross-section diameter of the gasket.

12-3

ABS Solid Wall Pipe - Pipe, fittings, and joints shall comply with ASTM D 2751, except as modified herein. The minimum wall thickness shall be as specified by SDR 23.5.

Joint solvent cement shall be an ABS cement conforming to ASTM D 2235. Gaskets shall conform to the requirements of Part IV, the subsection entitled "Gaskets for PVC Pipe."

12-3.1

Material Composition and Testing - ABS resin shall contain polymers or blends of polymers in which the weight percentage shall range from 40 to 70 for styrene, 8 to 16 for butadiene, and 18 to 35 for acrylonitrile. These weight percentages of styrene, butadiene, and acrylonitrile shall add up to 100 in any specific resin. Additives, such as stabilizers, antioxidants, lubricants, colorants, etc., shall not exceed 10 parts by weight per 100 of ABS resin in the compound.

The District may, at any time, direct the manufacturer to obtain compound samples and to prepare injection molded test specimens in accordance with ASTM D 1897. These specimens shall comply with the minimum property values as follows:

<u>Property</u>	<u>ASTM Test Method</u>	<u>Initial Values</u>	<u>After 112 Days Exposure</u>
Tensile Strength	D 638	5,000 psi, min	5,000 psi, min
Impact Strength	D 256 Method A Size 1/2" x 1/8" x 2-1/2"	2 ft-lbs/in of notch, min	2 ft-lbs/in of notch, min
Weight Change	D 543		
Unconditioned			+1.5%, max
Conditioned			±1.0%, max

Tensile and impact exposure specimens shall be immersed in the following solutions for a period of 112 days:

<u>Chemical Solution</u>	<u>Concentration</u>
Sulphuric acid	20%*
Sodium hydroxide	5%
Ammonium hydroxide	5%*
Nitric acid	1%
Ferric chloride	1%
Soap	0.1%
Detergent (linear alkyl benzyl sulfonate or LAS)	0.1%
Bacteriological	BOD not less than 700 ppm

---

\*Volumetric percentages of concentrated reagents of C.P. grade.

At four-week intervals, selected specimens shall be removed, washed, surface dried, and tested.

Weight change specimen shall be 2 inches in diameter and may be molded discs or discs cut from the pipe wall. They shall be conditioned for seven days at 43° +2° C, cooled in a desiccator for three hours at 23° +2° C, weighed, and then immersed in the above solutions. At four-week intervals, selected specimens shall be removed, washed, surface dried, and weighed. These same specimens shall then be reconditioned for seven days at 43° +2° C, cooled in a desiccator for three hours at 23° +2° C, and again weighed.

12-3.2

Pipe Acceptance - At the time of manufacture, each lot of pipe and fittings shall be inspected for defects and tested for impact, stiffness, and flattening in accordance with ASTM D 2751.

When testing subsequent to manufacture, the impact requirement shall be excluded. For the flattening requirement, the percentage reduction in pipe diameter shall be not less than 15% for pipe marked Standard Dimension ratio (SDR) 23.5 or lower and not less than 25% for pipe marked with higher SDR numbers. The stiffness requirement is unchanged.

The District may require certification by the manufacturer that the test results comply with specification requirements.

A pipe lot shall consist of all pipe having the same marking number. The lot test specimen shall have a minimum length of 4 feet.

12-3.3 Marking - Pipe shall have a home mark to indicate full penetration of the spigot when the joint is made. Pipe shall be marked at 5-foot intervals or less with a marking number which identifies the manufacturer, SDR, size, machine, date, and shift on which the pipe was produced.

12-3.4 Repair - There shall be no discontinuity of the pipe inner wall. Ruptures in the pipe outer wall may be repaired if the damage is limited to an area that can be encompassed by a 3-inch-diameter circle superimposed over the damage. Cell filler repair is unnecessary. A solvent welded ABS repair patch, at least equal to the thickness of the pipe outer wall, shall extend at least 1 inch beyond the damage. When damage exceeds these limits, the damaged section shall be cleanly cut off the pipe.

12-4 ABS Composite Pipe - Pipe, fittings, and joints shall comply with ASTM D 2680, except as modified herein.

The pipe shall consist of two concentric extruded thermoplastic tubes integrally connected by webs to form a circular truss. The longitudinal void spaces shall be filled with inert material.

Joint solvent cement shall be in accordance with ASTM D 2235. Gaskets shall conform to the requirements of Part IV, Subsection C-2.5, entitled "Gaskets for PVC Pipe."

12-4.1 Material Composition and Testing - The ABS compound used in the manufacture of ABS composite pipe shall conform to the requirements of the subsection entitled "Material Composition and Testing" for ABS solid wall pipe.

12-4.2 Pipe Acceptance. Each lot of pipe and fittings shall be inspected for defects and tested for stiffness and deflection in accordance with ASTM D 2680. The District may require certification by the manufacturer that the test results comply with specification requirements.

A pipe lot shall consist of all pipe having the same marking number. The lot test specimen shall be a minimum length of 4 feet.

12-4.3 Marking and Repair - Pipe shall have a home mark to indicate full penetration of the spigot when a joint is made. Pipe shall be marked at 5-foot intervals or less with a marking number which identifies the manufacturer, size, machine, date, and shift on which the pipe was produced.

Repair shall conform to the requirements of the subsection entitled "Repair" for ABS solid wall pipe.

12-5

Bedding - Minimum bedding of PVC or ABS sewer pipe shall be as shown on Standard Drawing S-6. Normal bedding shall be used for depth of cover as follows:

<u>Type of Pipe</u>	<u>Depth of Cover, C</u>
PVC	4' C <u>    </u> 17'
ABS composite or solid wall	4' C <u>    </u> 20'

Bedding for depth of cover less than 4 feet for all plastic pipe materials or greater than 17 feet for PVC pipe or greater than 20 feet for ABS composite and solid wall pipe shall be determined by the District.

Crushed rock for pipe bedding shall be the product of crushing rock or gravel. Fifty percent of the particles retained on a 3/8-inch sieve shall have their entire surface area composed of faces resulting from fracture due to mechanical crushing. Not over 5% shall be particles that show no faces resulting from crushing. Less than 10% of the particles that pass the 3/8-inch sieve and are retained on the No. 4 sieve shall be waterworn particles. Gravel shall not be added to crushed rock.

The material shall have the following gradation:

<u>Sieve Size</u>	<u>3/4-Inch- Max-Crushed Rock % Passing</u>
1-1/2"	-
1"	100
3/4"	90-100
1/2"	30-60
3/8"	0-20
No. 4	0-5
No. 8	-

## SECTION 13

### PORTLAND CEMENT CONCRETE

13-1 General and Classes - All portland cement concrete shall conform to the provisions of Section 90 of the State Specifications except as herein modified.

The cement content for the various classes of concrete shall be as follows:

- (1) Class A concrete shall contain a minimum of 564 pounds, six sacks, of portland cement per cubic yard and shall attain a minimum 3,000-psi compressive strength at 28 days when tested in accordance with ASTM C 39.
- (2) Class B concrete shall contain a minimum of 470 pounds, five sacks, of portland cement per cubic yard and shall attain a minimum 2,000-psi compressive strength at 28 days when tested in accordance with ASTM C 39.

Portland cement concrete shall have a slump of 4 to 5 inches for vertical wall sections and columns or as directed by the District Inspector. Portland cement concrete for slabs, footings, beams, and other miscellaneous concrete work shall have a slump of 3 to 4 inches or as directed by the District Inspector.

13-2 Cement - Portland cement, including portland cement used in precast products, shall be Type II or Type V, conforming to the specifications of ASTM C 150.

13-3 Portland Cement Concrete - Portland cement concrete shall be composed of portland cement, fine aggregate, coarse aggregate, and water proportioned and mixed to produce a smooth, dense, workable mixture. It can be of the ready-mix variety as produced by any reliable ready-mix concrete firm.

13-4 Reinforcing - Reinforcing steel shall be deformed bars from new billet stock or intermediate grade conforming to the requirements of the latest revision of ASTM A 15 and A 305 and shall be of the required sizes and shapes and placed where shown on the drawings or prescribed by the District Engineer. The reinforcement shall be so secured in position that it will not be displaced during the depositing of concrete. All reinforcing steel shall be completely encased in concrete. Wire mesh shall conform to ASTM A 185. All bars shall be bent cold and at the time of concrete placement, they shall be free from rust, scale, oil, or any other coating which would reduce or destroy the bond between concrete and steel. Minimum lap for all reinforcement shall be 20 bar diameters.



SECTION 14

PRECAST REINFORCED PORTLAND CEMENT CONCRETE MANHOLES

- 14-1            General - Precast reinforced portland cement concrete manhole risers and tops shall be constructed of Class A concrete and shall conform to the specifications of ASTM C 478, except as herein modified.

Southwest Concrete Products and Inland Concrete Products precast manholes shall be equal in all respects to those manufactured by Associated Concrete Products, Santa Ana, California, or centrifugally spun manhole units as manufactured by Ameron, South Gate, California, or approved equal. The Contractor is required to submit shop drawings of the precast manhole he proposes to use for the approval of the District Engineer.

- 14-2            Fabrication - The minimum nominal shell thickness for formed and vibrated sections shall be 1/8 of the internal diameter of the riser or largest cone diameter.

Manholes shall be fabricated only from eccentric taper sections and standard cylinder units of the proper internal diameter. The minimum allowable steel shall be hoops of No. 4 wire, to be cast into each unit at adequate places as precautionary measure for handling. Steel ladder rungs shall not be installed in manhole sections.

## SECTION 15

### MANHOLE FRAMES AND COVERS

15-1

General - Castings for frame and cover sets shall conform to the requirements for gray iron castings in ASTM A 48 for Class 30 castings. Frames and covers shall be designed for H-20 loading. Before leaving the foundry, all castings shall be thoroughly cleaned and subjected to a hammer inspection, after which they shall be dipped twice in a preparation of asphalt or coal tar and oil applied at a temperature of not less than 290° F or more than 310° F and in a manner that forms a firm and tenacious coating. Each cover shall be ground or otherwise finished so that it will fit in its frame without rocking, and frames and covers shall be match-marked in sets before shipping to the site. Covers shall have the word "SEWER" and the initials "OCSD" cast thereon as shown on Standard Drawing S-1. No other lettering on the top side will be permitted. Shop drawings of all manhole rings and covers shall be submitted to the District Engineer.

## SECTION 16

### STEEL CASING PIPE

16-1

General - New steel casing pipe, unless otherwise approved by the District Inspector, shall be butt-welded sheets conforming to ASTM A 245, commercial grade or of plate conforming to ASTM A 283. All field joints shall also be butt-welded full circumference or by other means approved by the District Engineer. A jacking band to reinforce the end of the pipe receiving the jacking thrust will be required. It shall be the Contractor's responsibility to provide joints that are capable of resisting the jacking stresses without failure. The minimum size and thickness of casing pipes for insertion of various sizes of plastic sewer pipe shall be as follows, unless a larger or heavier wall casing pipe is required by the agency having jurisdiction over the road or railroad crossing:

<u>PVC or ABS Size (inches)</u>	<u>Min. ID Casing Size (inches)</u>	<u>Min. Wall Thickness (inches)</u>
4	10	1/4
6	12	1/4
8	16	1/4
10	18	5/16
12	20	5/16

<u>V.C.P. Size (inches)</u>	<u>Min. ID Casing Size (inches)</u>	<u>Min. Wall Thickness (inches)</u>
4	14	1/4
6	16	1/4
8	18	1/4
10	21	5/16
12	24	5/16

Cathodic protection of the steel casing pipe may be required if specified by the District Engineer.

SECTION 17

EPOXY RESIN

17-1

General - All approved saddle connections or repair work to District sewer mains shall be accomplished with one of the following epoxy resins:

EPIBOND 157 as manufactured by Furane Plastics Incorporated, 4516 Brazil Street, Los Angeles, California; WR633 A & B as manufactured by Wyndham Chemicals Incorporated, 10640 South Painter Avenue, Santa Fe Springs, California; EPON 828 as manufactured by the Shell Chemical Corporation obtainable from Pacific Clay Products Corporation, Los Nietos, California; or approved equal.

The epoxy resin shall be used in strict accordance with the manufacturer's recommendations.

# I N D E X

## PART III - METHODS OF CONSTRUCTION

	<u>PAGE</u>
SECTION 100 - EARTHWORK	1
100-1 General	1
100-2 Excavation	1
100-2.1 Clearing and Grubbing	1
100-2.2 Excavation	1
100-2.2.1 Limit of Excavation	2
100-2.2.2 Trench Width	2
100-2.2.3 Bracing	2
100-2.2.4 Correction of Faulty Grades	3
100-2.3 Grading and Stockpiling	3
100-2.4 Dewatering	3
100-2.5 Granular Soil	3
100-3 Trench Bottom for Vitriified Clay Pipe	4
100-3.1 Foundations in Rock	4
100-3.2 Foundations in Unsuitable Material	4
100-3.3 Foundation in Suitable Soil	4
100-4 Trench Backfill	4
100-4.1 Pipe Bedding	5
100-4.1.1 Procedure at Pipe Zone	5
100-4.2 Backfill above Pipe Zone	5
100-4.2.1 Compaction in Open Fields	5
100-5 Backfill at Street Zone	6
100-6 Compaction	6
100-7 Consolidation	6
100-8 Compaction Requirements	6
100-9 Excess Excavated Material	7
100-10 Imported Backfill Material	7
100-11 Structure Excavation and Backfill	7
100-11.1 Structure Excavation	7
100-11.2 Structure Backfill	8

PART III - METHODS OF CONSTRUCTION INDEX - Continued

	<u>PAGE</u>
100-11.2.1 Material	8
100-11.2.2 Compaction	8
100-12 Final Clean-Up	8
SECTION 101 - VITRIFIED CLAY PIPE AND FITTINGS	1
101-1 Laying Vitrified Clay Pipe	1
101-1.1 Flexible Compression Joints	1
101-1.2 Preventing Foreign Matter from Entering the Pipe	1
101-1.2.1 Branches	1
101-2 Saddle Connections	2
101-2.1 Saddle Installation	2
SECTION 102 - HOUSE LATERALS	1
102-1 General	1
102-2 Location of House Laterals	1
SECTION 104 - MANHOLES	1
104-1 General	1
104-2 Manhole Base	1
104-2.1 Manhole Invert	1
104-3 Precast Manholes	1
104-4 Manhole Stubs and Stoppers	2
104-5 Watertightness of Manholes	2
104-6 Manhole Frame and Cover	2
104-7 Drop Manholes	2
SECTION 105 - STEEL CASING PIPE	1
105-1 General	1
105-1.1 Installation	1
105-1.1.1 General	1
105-1.1.2 Jacking and Boring	1
105-2 Carrier Pipe within Casing Pipe	2

PART III - METHODS OF CONSTRUCTION INDEX - Continued

	<u>PAGE</u>
SECTION 106 - CONCRETE ENCASEMENT	1
106-1 General	1
SECTION 107 - REMOVAL AND RESURFACING OF STREET PAVEMENT AND SURFACES	1
107-1 General	1
SECTION 108 - RAILROAD CROSSINGS	1
108-1 General	1
SECTION 109 - TESTING	1
109-1 Test for Leakage and Infiltration	1
109-1.1 General - For Either V.C.P. or Plastic Sewer Pipe	1
109-1.2 Type Tests for V.C.P.	1
109-1.3 Type Tests for Plastic Sewer Pipe	6
109-1.4 Manhole Test	6
109-1.5 Test for Damaged or Defective V.C.P. in Place	7
109-1.6 Test for Damaged or Defective Plastic Sewer Pipe in Place	7

PART III

METHODS OF CONSTRUCTION

SECTION 100

EARTHWORK

100-1

General - Earthwork shall include all necessary clearing, grubbing, grading, and excavation for pipelines and appurtenances, backfilling, compaction, and disposal of excess excavated material all as required for the complete performance of the work for the installation of sewers, manholes, special structures, and appurtenances all as indicated on the Plans and as specified herein.

Earthwork, including grading, as referred to herein or in connection herewith, shall be construed as including any or all of the following described operations:

Clearing of the construction site; excavation of all classes and of whatever substance encountered; backfilling; fine grading as finish for unpaved areas; preparation of right of way, subgrade for pipe, structures, and paving; and performing any other similar, incidental, or appurtenant earthwork operation which may be necessary to properly complete the entire work indicated and specified.

100-2

Excavation

100-2.1

Clearing and Grubbing - Areas, where work is to be performed, shall be cleared of all trees, shrubs, rubbish, and other objectionable material of any kind which, if left in place, would interfere with the proper performance or completion of the contemplated work, would impair its subsequent use, or form obstructions therein.

Organic material from clearing and grubbing operations will not be incorporated in excavation backfill.

100-2.2

Excavation - Excavation for sewer pipe, fittings, and appurtenances shall be open trench to the depth and in the direction necessary for the proper installation of the same as shown on the Plans or as otherwise approved by the Engineer. Any water which may be encountered or may accumulate in the excavation shall be pumped out or otherwise removed as necessary to keep the bottom of the excavation free and clear of water during the progress of the work.



Tunneling may be permitted as indicated by economy of construction or necessity of preserving existing improvements. If the earth in the tunnel sloughs off, the roof of the tunnel shall be broken down, and the trench excavated as an open trench.

100-2.2.1

Limit of Excavation - Except by special permission of the Engineer, the maximum length of open trench shall not exceed 1,500 feet in the aggregate at any one location including excavation, construction, pipe laying and embankment. Orange County Highway Department requirements shall prevail.

100-2.2.2

Trench Width - The overall trench width shall not be more than sixteen inches (16") or less than twelve inches (12") wider than the largest outside diameter of the pipe to be laid therein, measured at a point twelve inches (12") above the top of the pipe exclusive of branches. Excavation and trenching shall be true to line so that a clear space of not more than eight inches (8") or less than six inches (6") in width is provided on each side of the largest outside diameter of the pipe in place. For the purpose of this article, the largest outside diameter shall be the outside diameter of the bell, on bell and spigot pipe.

Where the trench width, measured at a point twelve inches (12") above the top of the bell of the pipe, is wider than the maximum set forth above, the trench area around the pipe shall be backfilled with Class "C" concrete to form a cradle for the pipe as shown on the Detail Drawings.

100-2.2.3

Bracing - The contractor shall take the necessary precautions to be consistent with the rules, orders and regulations of the Division of Industrial Safety of the State of California. Excavations shall be so braced, sheeted and supported that they will be safe, and the ground alongside the excavation will not slide or settle, and all existing improvements of any kind, either on public or private property, will be fully protected from damage. The sheeting, shoring and bracing shall be so arranged as not to place any stress on portions of the completed work until the general construction thereof has proceeded far enough to provide ample strength. Care shall be exercised in the drawing or removal of sheeting, shoring, bracing and timbering to prevent the caving or collapse of the excavation faces which are being supported.

100-2.2.4

Correction of Faulty Grades - Where excavation is inadvertently carried below subgrade and/or foundation elevations, suitable provision shall be made by the Contractor for adjustment of same, as directed by the Engineer, to meet requirements incurred by the deeper excavation beneath pipe or structures. Overdepth excavation in such locations shall be rectified by backfilling with approved and/or graded gravel, and shall be compacted to provide a firm and unyielding subgrade and/or foundation, as directed by the Engineer.

100-2.3

Grading and Stockpiling - The Contractor shall control grading in a manner to prevent water running into excavations. Obstruction of surface drainage shall be avoided and means shall be provided whereby storm and wastewater can flow uninterrupted in existing gutters, other surface drains, or temporary drains.

100-2.4

Dewatering - The Contractor shall provide and maintain at all times during construction ample means and devices with which to promptly remove and properly dispose of all water from any source entering the excavations or other parts of the work. Dewatering shall be accomplished by methods which will ensure a dry excavation and preservation of the final lines and grades of the bottoms of excavations. Said methods may include well points, sump points, suitable rock or gravel placed below the required bedding, for drainage and pumping purposes, temporary pipe lines and other means, all subject to the approval of the Engineer.

Dewatering for the structures and pipelines shall commence when groundwater is first encountered, and shall be continuous until such times as water can be allowed to rise in accordance with the provisions of this Section. No concrete footings or floors shall be laid in water nor shall water be allowed to rise over them until the concrete or mortar has set at least eight (8) hours. Water shall not be allowed to rise unequally against walls for a period of twenty-eight (28) days. Groundwater shall not be allowed to rise around the pipe until jointing compound in the joints has set hard.

100-2.5

Granular Soil - Wherever the term "granular soil" is used in these Specifications it shall be defined as a soil having a minimum sand equivalent of 30 as determined in accordance with State of California, Division of Highways, Test No. "California 217," and not more than 20% of it will pass through a 200 mesh sieve.

100-3

Trench Bottom for Vitrified Clay Pipe:- The trench bottom shall be graded to provide a smooth, firm and stable foundation at every point throughout the length of the pipe.

At each joint in the pipe, the bottom of the trench shall be recessed in the firm foundation in such a manner as to relieve the bell of the pipe of all load, and to insure continuous bearing along the pipe barrel upon the firm foundation. Should large gravel and cobbles be encountered at the trench bottom or pipe subgrade, they shall be removed from beneath the pipe and replaced with clean granular material which shall be compacted to provide uniform support and a firm foundation. The Contractor shall be responsible for accurately shaping the pipe subgrade and fitting the bottom of the pipe to the excavation for the width shown on the "Bedding Details." Use of a drag templet shaped to conform to the outer surface of the pipe will be required if other methods do not give satisfactory results.

100-3.1

Foundations in Rock - Where rock is encountered, it shall be removed below grade and the trench backfilled with clean imported sand to provide a compacted foundation cushion with a minimum allowable thickness of three inches (3") under the outside diameter of the pipe bell.

100-3.2

Foundations in Unsuitable Material - If excessively wet, soft, spongy, unstable or similarly unsuitable material is encountered at the surface upon which the bedding material is to be placed, the unsuitable material shall be removed to a depth as determined in the field by the Engineer.

100-3.3

Foundation in Suitable Soil - Where the trench excavation and pipe foundation and/or subgrade consists of granular or sandy material, the pipe shall be bedded in the material found in the trench as hereinafter specified. In the event the trench excavation material and pipe foundation are not an acceptable granular material for bedding an imported or selected granular material shall be used for bedding. In all cases, the material to be used for pipe bedding will be subject to the approval of the Engineer.

100-4

Trench Backfill - All trenches shall be backfilled after pipe, fittings and appurtenances have been installed. Whenever a relative compaction requirement value is specified herein, the optimum moisture content and relative density shall be determined in accordance with State of California, Division of Highways, Test No. "California 216."

All wood and waste material shall be removed from excavation preparatory to backfilling. Backfill material shall be approved in all cases by the Engineer and shall be free of trash, wood, large rock, or other objectionable debris. Backfilling shall include the refilling and compacting of the fill in trenches or excavations up to the subgrade of the street or to the existing ground surface.

100-4.1

Pipe Bedding - The pipe shall be carefully bedded by hand placing and compacting and/or consolidating select or imported granular backfill material from the pipe foundation to the upper limit of the pipe zone. The pipe zone shall be considered to extend from the pipe foundation to twelve inches (12") above the top of the outside diameter of the pipe bell. Imported granular material will be used for pipe bedding when excavated materials are not suitable or when required by the bedding detail indicated on the construction Drawings.

100-4.1.1

Procedure at Pipe Zone:- Selected backfill material consisting of loose earth or sand free from stones, clods, or other deleterious material shall be placed in the trench simultaneously on each side of the pipe for the full width of the trench in layers of about six inches (6") in depth. Each layer shall be thoroughly compacted, or consolidated when approved by the Engineer, to a relative density of ninety percent (90%). Care shall be exercised in backfilling to avoid damage to the pipe.

100-4.2

Backfill above Pipe Zone - The remaining portion of the trench to within two and one-half feet (2-1/2') of the roadway surface or ground surface, as the case may be, shall be backfilled, compacted and/or consolidated by approved methods to obtain a relative density of ninety percent (90%). Backfilling shall be done with good, sound earth, sand or gravel, and no oil cake, bituminous pavement, concrete, rock or other lumpy material shall be used in the backfill, unless these materials are scattered and do not exceed six inches (6") in any dimension, and are not placed within 1-foot of the 2-1/2-foot limit. Material of a perishable, spongy or otherwise improper nature shall not be used in backfilling, and no material greater than four inches (4") in any dimension shall be placed within 1-foot of any pipe, manhole or structure.

100-4.2.1

Compaction in Open Fields - In open fields across private property within District easements, where paving or structures will not be above the excavated area, backfill above the "pipe zone" to the top of trench shall be compacted and/or consolidated by approved methods to obtain a density equal to the density of the adjacent undisturbed soil but not less than a relative density of eighty-five percent (85%). Where backfilling is to support paving or structures a compaction of ninety percent (90%) relative density shall be attained.

100-5

Backfill at Street Zone - The top two and one-half feet (2-1/2') of the trench within road bed areas shall be compacted in horizontal layers not exceeding eight inches (8") in thickness, using approved hand, pneumatic or mechanical type tampers to obtain a relative density of ninety percent (90%). Flooding and jetting will not be permitted in this upper two and one-half feet (2-1/2').

From existing street grade to two and one-half feet (2-1/2') below street grade, the material for backfill may contain stones ranging in sizes up to two inches (2") in diameter in quantity not exceeding twenty percent (20%) of the volume where said course materials are well distributed throughout the finer material and the specified compaction can be obtained.

100-6

Compaction - Compaction shall be done by use of vibratory equipment, tamping rollers, pneumatic tire rollers, or other mechanical tampers of the type and size approved by the Engineer. The backfill shall be placed in horizontal layers of such depths as are considered proper for the type of compacting equipment being used in relation to the backfill material being placed. Each layer shall be evenly spread, properly moistened and compacted to the specified relative density in paragraph 100-4.2.1. The Contractor shall repair or replace any sewer pipe, fittings, manholes, and/or structures as directed by the District where damaged by the Contractor's operations.

100-7

Consolidation - Consolidated fill shall be performed by flooding, poling, or jetting so as to obtain a relative density of the fill material at least equal to that specified in paragraph 100-4.2.1. When flooding, poling or jetting methods are used, material for use as backfill shall be placed and consolidated in layers not exceeding four feet (4') in thickness. Flooding, poling or jetting methods shall be supplemented by the use of vibratory or other compaction equipment when necessary to obtain the required relative density. Care shall be taken in all consolidating operations to prevent the movement or floating of the sewer pipe. Consolidation methods shall not be used where the backfill material is not sufficiently granular in nature to be self draining during and after consolidation, or where foundation materials may be softened or otherwise damaged by the quantities of water applied. The Contractor shall rectify any misalignment of the pipe because of consolidation operations as directed by the District.

100-8

Compaction Requirements - The Contractor will engage the services of an approved testing laboratory to determine the relative density of the backfill. The relative density shall be determined in accordance with the methods specified by the State of California, Division of Highways, Test No. "California 216".

If the backfill fails to meet the relative density requirements set forth herein, the Contractor shall rework the backfill until the requirements are complied with. The Contractor shall make all necessary excavations for density tests as directed by the Engineer. Orange County Highway Department requirements shall prevail.

100-9

Excess Excavated Material - The Contractor shall make the necessary arrangements for, and shall remove and dispose of all excess excavated material.

It is the intent of these Specifications that all surplus material not required for backfill or fill shall be disposed of by the Contractor outside the limits of the public rights of way and/or easements.

No excavated material shall be deposited on private property unless written permission from the owner thereof is secured by the Contractor. Before the District will accept the work, the Contractor shall file a written release signed by all property owners with whom he has entered into agreements for disposal of excess excavated material absolving the District from any liability connected therewith.

100-10

Imported Backfill Material - Whenever the excavated material is not suitable for backfill, the Contractor shall arrange for and furnish suitable imported backfill material, which is capable of attaining the required relative density. He shall dispose of the excess trench excavation as specified in the preceding section. The backfilling with imported material shall be done in accordance with the methods described herein.

100-11

Structure Excavation and Backfill

100-11.1

Structure Excavation - Structure excavation shall include the removal of all material of whatever nature necessary for the construction of structures and foundations in accordance with the Plans and these Specifications. The sides of excavations for structures shall be sufficient to leave at least two feet (2') in the clear as measured from the extreme outside of form work or the structure as the case may be. Where excavation is inadvertently carried below designated elevations, suitable provision shall be made by the Contractor for adjustment of construction, as directed by the Engineer, to meet requirements incurred by the deeper excavation. No earth backfill will be permitted to correct overdepth excavation beneath structures, and overdepth excavation in such locations shall be rectified by backfilling with sand, graded gravel, or concrete as directed by the Engineer.

100-11.2

Structure Backfill - After structures and foundations are in place, backfill shall be placed to the original ground line or to the limits designated on the Plans. No material shall be deposited against the walls of concrete structures for a period of fourteen (14) days following pouring of concrete.

100-11.2.1

Material - Backfill material shall consist of loose earth or sand free from stones, clods, or other deleterious material. When material from the excavation is unsuitable for use in backfill, it shall be disposed of as specified in Section 100-9 above, and suitable material, which is capable of attaining the required relative density, shall be used in its place.

100-11.2.2

Compaction - Backfill shall be placed in horizontal layers not exceeding six inches (6") in depth and shall be moistened and thoroughly tamped, rolled or otherwise compacted to a minimum relative density of ninety percent (90%) in accordance with the provisions of paragraph 100-4 above. Water settling will not be permitted except with the written permission of the Engineer.

100-12

Final Clean-Up - After backfill has been completed, the right of way shall be dressed smooth and left in a neat and presentable condition.

## SECTION 101

### VITRIFIED CLAY PIPE AND FITTINGS

#### 101-1 Laying Vitrified Clay Pipe

Trenches shall be kept free of water during the laying operation and until the material in the joints has sat sufficiently to preclude any damage. All pipe shall be laid without break, upgrade from structure to structure, with the bell ends of the pipe upgrade. Pipe shall be laid to the line and grade given and in such a manner as to form a close concentric joint with the adjoining pipe and prevent sudden offsets of the flow line. The interior of the sewer pipe shall be cleaned of all dirt and superfluous materials of all description as the work progresses. The provisions of Section 100 of these Specifications shall apply to the installation of the pipe.

#### 101-1.1 Flexible Compression Joints

The Contractor shall wipe the mating surfaces of the pipe to be joined clean of all dirt and foreign matter, and apply an approved lubricant. Then, with the surfaces properly lubricated, the Contractor shall position the spigot end of the pipe inside the bell and shove the joint home. For larger diameter pipe where a lever attachment is required the Contractor shall take the necessary precautions to insure an undamaged pipe installation.

#### 101-1.2 Preventing Foreign Matter from Entering the Pipe

At times when the pipe laying is not in progress, the open end of the pipe shall be closed with a tight-fitting cap or plug to prevent the entrance of foreign matter into the pipe. These provisions shall apply during the noon hour as well as overnight. In no event shall the sewers be used as drains for removing water which has infiltrated into the trenches.

#### 101-1.2.1 Branches

Vitrified clay pipe wyes, tees, and other types of branches shall be furnished and installed along with vitrified clay pipe sewer. Wyes of size specified on the Plans shall be installed for all sewer house connections and for future sewer house connections as shown on the Plans. Tees shall be installed for chimneys shown on the Plans. The longitudinal barrel of branch fittings, to be placed in-line and grade with the vitrified clay pipe sanitary sewer mains, shall be of the same diameter, quality and type as said sewer. Installation, earthwork and bedding for branches shall conform to the applicable provisions set forth for



vitriified clay sewer pipe. Tee branches shall have their axis perpendicular to the longitudinal axis of the pipe. Unless otherwise specified, the branch of wye fittings shall be inclined upward at an angle not greater than forty-five degrees (45°) from a horizontal line. If so shown on the Plans, tees with standard tee foundations shall be substituted for wye branches. No wye or tee for sewer house connections branch shall be placed closer than five feet (5') in the downstream side, to the centerline of any structure.

The Contractor shall place a support of No. 4 crushed rock under every wye branch when installed. The support shall be placed in accordance with the detail on the Plans.

101-2

#### Saddle Connections

All saddle connections into existing sewer lines shall be made with a collar wye saddle and no saddle connection smaller than four inches (4") nor larger than six inches (6") will be permitted. All connections into a 27-inch or larger sewer line shall be made at a structure.

The quality of the vitriified clay pipe saddles shall conform to the applicable provisions of Section 11 of these Specifications. Joints for the saddles shall conform to Section 11-2 of these Specifications.

101-2.1

#### Saddle Installation

The sewer line to be saddled shall be scored to the approximate shape of wye or tee and shall be cut with a circular ceramic saw of 2", 4", 6" and 8" diameter. The resulting opening into the sewer line shall be further worked by hand to accomplish a true and neat opening for the collar wye or tee saddle. The Contractor shall replace or repair any pipe damaged during his operation, and the Engineer shall be the sole judge as to how the repair or replacement should be accomplished.

The Contractor shall secure the collar wye or tee saddle to the sewer main with a catalytic epoxy resin as specified in Section 17 of these Specifications.

After the connection has set sufficiently long enough for the epoxy resin to cure, the District will inspect the connection and if satisfactory the Contractor shall encase the fitting with Class "A" Portland cement concrete to the limits indicated on the Detail Drawings.

The Contractor shall carry out the saddling operation only in the most workmanlike manner, and he shall keep all clay chips, dirt, epoxy, mortar, and concrete out of the sewer line being saddled. The Contractor shall, if directed to do so by the District, perform a flushing, cleaning, and balling operation of the reach of sewer main saddled.

As an alternate method of cutting an opening in the sewer line, the Contractor may chip the opening by following the procedure outlined below:

The main line sewer shall be scored to the approximate shape of the collar wye saddle or collar tee saddle. A small hole, not larger than one-inch in diameter, shall be made in the approximate center of the area to be cut from the sewer line with a pointed tool similar to a mason's pick. Then the opening shall be chipped to the scored line in a spiraling fashion with a chisel and a short handle, hand-held hammer. The Contractor shall replace or repair any pipe damaged during his operation, and the Engineer shall be the sole judge as to how the repair or replacement should be accomplished.

## SECTION 102

### HOUSE LATERALS

102-1

#### General

The Contractor shall install house laterals and wye branch fittings of the size indicated on the Plans and shall install the house laterals at the recommended location for each lot as furnished by the Owner.

The Contractor shall place as many wye branch fittings for house laterals as may be designated on the Plans. Each wye branch fitting shall have its barrel diameter equal to the diameter of the sanitary sewer main and the spur (or branch) diameter as indicated on the Plans. No wye branch shall be placed closer than five feet (5') on the downstream side, to the centerline of any structure. All wye branch fittings that are to be left unconnected shall be plugged with a vitrified clay disc stopper or plug. House laterals shall be joined to wye branch fittings at the sanitary sewer main as set forth above by eighth bends. All eighth bends and quarter bends are a part of house lateral sewer line.

Where possible all house laterals shall run perpendicular to the sewer main from the main to the property line, and all house laterals shall be bedded the same as the sewer main into which they connect.

All house laterals shall be plugged with an approved stopper in the socket of the last joint of each house lateral which shall be securely sealed in place with Sewer Joint Compound, as specified in Section 11 of these Specifications, so that it will withstand the internal pressure during the test for leakage, but also in such a manner that it may be removed without injury to the socket.

102-2

#### Location of House Laterals

The Contractor shall mark the location of each house lateral at its upper end by chiseling a letter "S" one and one-half inches ( $1\frac{1}{2}$ "') high on the top of the curb. If the terminal point of the house lateral is more than eight feet (8') beyond the curb line or curb improvements do not exist, the Contractor shall furnish and install a wood stake at the end of the house lateral in conformance with the Detail Drawings.

Where curb improvements are installed after the house laterals are laid, and before the District accepts the sanitary sewers, the Contractor shall chisel the 1-1/2-inch "S" on the top of the curb before acceptance.

## SECTION 104

### MANHOLES

104-1

#### General

Sewer manholes shall be constructed in accordance with the Detail Drawings and of the size indicated at the locations shown on the Plans. The manholes shall be constructed of precast eccentric concrete manhole units or built-in-place brick in accordance with the Detail Drawings and these Specifications. Manholes shall be built without steps.

104-2

#### Manhole Base

The manhole base shall be poured in place with Type II, Portland cement concrete. The manhole stubs and sewer main shall be set before the concrete is placed and shall be rechecked for alignment and grade before the concrete has set. The various inlets and outlets to the manhole shall be located as indicated on the Plans and as detailed in the Detail Drawings. All transitions shall be smooth and of the proper radius to give an uninterrupted transition of flow. The concrete shall be Class "A" concrete with 3/4-inch maximum size aggregate and shall have a slump not greater than two inches (2"). The concrete base shall be shaped with a wood float and shall receive a hard steel trowel finish prior to the concrete setting. The bases shall set a minimum of twenty-four (24) hours before the manhole construction is continued.

104-2.1

#### Manhole Invert

The invert of the manhole base shall be hand worked so as to provide channels conforming in size and shape to the lower portions of the inlets and outlets. The channel shall vary uniformly in size and shape from inlet to outlet, and be constructed as indicated on the Detail Drawings. The manhole invert channels shall be smooth and accurately shaped. Channels may be formed directly in the concrete base or may consist of one-half sewer tile laid in the concrete base.

104-3

#### Precast Manholes

Each manhole section shall be set in a bed of mortar to make a watertight joint and shall be neatly pointed on the inside and shall be set perfectly plumb. Sections of various heights shall be used in order to bring the top of the manhole ring and cover to the elevation established by the Engineer.

The precast concrete manhole rings shall be jointed with a minimum thickness of 1/2-inch of Portland cement mortar. Mortar shall be composed of one (1) part Portland cement to two (2) parts of clean well-graded sand of such size that all pass a number eight (8) sieve. Cement, aggregate, and water for mortar shall conform to the applicable provisions of Section 12 of these Specifications.

- 104-4      Manhole Stubs and Stoppers - Vitrified clay pipe stubs shall be furnished and installed in manholes at the locations and in conformance with the Detail Drawings and as shown on the Plans. All stubs shall be plugged with stoppers or brick wall plugs as shown on the Plans for various sizes of pipe. Where new construction is started at the stub of an existing manhole the contractor shall brick the opening into the manhole before he removes the plug or stopper from the stub. Said bricked opening shall remain in place until the Contractor has tested and completed the work.
- 104-5      Watertightness of Manholes - It is the intent of these Specifications that manholes and appurtenances be as watertight and free from infiltration as possible. Where manholes are to be given a protective lining or coating, they shall be free of any seeping or surface moisture. The adequacy of manholes and appurtenances as to watertightness shall be determined by the Engineer, and shall be tested by filling with water when ordered by the Engineer.
- 104-6      Manhole Frame and Cover - The elevations at which manhole frames and covers are to be set shall conform to the requirements set forth on the Plans and Detail Drawings but in all cases shall be governed by the Engineer in the field. Where the frame and cover are in existing pavement or in the traveled way of the existing road shoulder, it is to be placed flush with the existing surface. Where the structure is outside the limits of the traveled shoulder but not in the roadside ditch, it should be placed 1/10-foot or more above the existing ground surface. Where the manhole cover falls in the existing roadside ditch or right-of-way, it is to be placed approximately 1-1/2 foot above the existing ground surface or as directed by the Engineer. Manhole frames shall be set at the required grade and shall be securely attached to the top precast manhole shaft unit with a cement mortar bed and fillet as shown on the Plans. After the frames are securely set in the place provided herein, covers shall be installed and all necessary cleaning and scraping of foreign materials from the frames and covers shall be accomplished to insure a fine satisfactory fit.

## SECTION 105

### STEEL CASING PIPE

105-1

General - Steel casing pipe shall be installed at the locations and to the lines and grades indicated on the Plans and as herein specified. All work shall conform to the specifications and requirements of the State of California, Division of Highways, the Orange County Highway Department, the City, and/or the railroad company involved. It shall be the Contractor's responsibility to secure all necessary permits for start and prosecution of casing pipe installation.

105-1.1

#### Installation

105-1.1.1

General - The equipment, materials and methods used for the construction of the complete installation of the casing pipe and the sewer pipe within the casing shall be determined by the Contractor to the extent that the final and completed installation receives the approval of the Engineer and is consistent with the intent of these Specifications.

The Contractor may present an alternate detailed proposal in lieu of the methods and materials specified herein to jack or bore casing pipe under the locations as shown on the Plans. Such proposal shall be subject to the sole approval of the Engineer and shall be presented FOURTEEN (14) CALENDAR DAYS in advance of the work to allow adequate time for checking and must be in accordance with all the conditions set forth in the necessary permits.

105-1.1.2

Jacking and Boring - Steel casing pipe of the minimum size and thickness specified herein, shall be installed in place by jacking and/or boring methods without the use of water or air at the locations shown on the Plans, and to grades required to install the vitrified clay carrier pipe. The Contractor's attention is called to the fact that extreme care will be required in placing the casing pipe so as to permit the construction of the sewer pipe to the lines and grades shown on the Plans. The sewer mains are gravity flow, designed at grades which will not permit variance from the lines and grades as shown. It shall be the Contractor's responsibility for choosing a size of casing, at or above the minimum specified, in order that the jacking may be done with a sufficient degree of accuracy to permit installation of the vitrified clay carrier pipe to the grades shown on the Plans.

In general, excavated material shall be removed from the casing as jacking progresses and no accumulation of excavated material within the casing will be permitted. Should appreciable loss of ground occur, the voids shall be back-packed promptly to the extent practicable with soil cement. Upon completion of the jacking operation and before the carrier pipe is installed, all voids around the casing shall be filled by grouting through holes drilled through the casing. The grout shall be a lean mixture of sand and cement placed at low pressures. After the carrier pipe has been installed, the annular space between the carrier pipe and the casing pipe shall be backfilled with lean grout under pressure. Sand will not be permitted for such backfilling. Lean grout shall be one (1) part of Portland cement to not more than four (4) parts of sand by volume. Grout at each end of the casing pipe shall be finished neat and flush with pipe end.

105-2

Carrier Pipe within Casing Pipe - Vitrified clay sewer pipe conforming to the Specifications of Section 11, shall be installed within the casing pipe to the lines and grades shown on the Plans. Mechanical compression joints shall be used on all vitrified clay sewer carrier pipe installed within casing pipe. The carrier pipe shall be supported on wood or metal skids prior to backfilling in such a manner as to relieve the pipe bells from all load and bearing. Prior to backfilling as specified above, said sewer carrier pipe shall pass a successful test for leakage as provided in Section 109.

SECTION 106

CONCRETE ENCASEMENT

106-1

General - Encasement concrete shall be either reinforced or non-reinforced, unformed or rough formed, and the Class as designated on the Plans. Concrete used for encasing, cradling, bedding, or cover for pipe, or other objects shall be as shown on the Plans and Detail Drawings or as directed by the Engineer.



SECTION 107

REMOVAL AND RESURFACING OF STREET PAVEMENT AND SURFACES

107-1

General - Street pavement and surfaces shall be removed and replaced in all areas of construction excavation in conformance with details shown on the Plans and as specified herein. Resurfacing of existing pavement and surfaces damaged or removed in connection with the construction of sanitary sewer improvements, including all appurtenances, shall conform to the provisions of permits issued by the State of California, Division of Highways, Orange County Highway Department, or the City, for the work within the rights of way of respective agency. In the absence of specific designation upon the Plans, the trench or excavation shall be resurfaced with the class of surfacing conforming most nearly to the surface of the street, and in accordance with the requirements, and to the full satisfaction of the agency issuing the permit.

The Contractor shall take precautions to prevent damage to all pavement and other surfaces outside the limits of necessary excavation, whether in City, County, or State right of ways, District right of ways, or private property. All damaged pavement and surfaces within City, County, or State right of ways shall be replaced in accordance with the conditions of the permits issued for the construction within the respective right of ways. The Contractor shall bear all expense in acquiring, and resulting from compliance with any and all conditions of the permits issued by the City, Orange County Road Department, and/or the State Division of Highways.

SECTION 108

RAILROAD CROSSINGS

108-1

General - The Contractor shall perform the work for the installation of the sewer lines under railroad tracks and across railroad right of way in accordance with the directions and under the supervision of the railroad company on whose property the work is done. It shall be the Contractor's responsibility to secure all necessary permits for start and prosecution of construction work on railroad property from the railroad company involved.

## SECTION 109

### TESTING

109-1

#### TEST FOR LEAKAGE AND INFILTRATION

109-1.1

General - For Either V.C.P. or Plastic Sewer Pipe - It is the intent of the plans and specifications that the completed sewer pipes of all types along with manholes and other appurtenances shall be watertight. Each section of sewer between two successive manholes shall be tested for leakage or, at the option of the District Inspector, for infiltration, or both. In general, the leakage test shall be made on all sections of sewer except those where, in the opinion of the District Inspector, excessive groundwater is encountered.

Where excessive groundwater is encountered, the infiltration test shall be made. Even though a section may have previously passed the leakage or infiltration test, each section of sewer shall be tested subsequent to the last backfill compacting operation if, in the opinion of the District Inspector, heavy compaction equipment or any of the operations of the Contractor or others may have damaged or affected the structural integrity or watertightness of the pipe, structure, and appurtenances. The Contractor shall furnish all materials required for the tests. Tests shall be made in the presence of the District Inspector.

Official inspector's test will not be made until after all the other utilities have been installed and their trench compaction verified.

If the leakage or infiltration rate as shown by the tests specified herein is greater than the amount specified, the pipe joints shall be repaired or, if necessary, the pipe shall be removed and relaid by the Contractor. The sewer will not be considered acceptable until the leakage or infiltration rate, as determined by test, is less than the maximum allowable.

109-1.2

Type Tests for V.C.P. - The following tests shall be applied to V.C.P.:

- (1) Air Test Procedure. Each section of sewer between two successive manholes shall be tested by plugging all pipe outlets with suitable test plugs. Air shall be slowly added until the internal pressure is raised to 4.0 psig. The compressor used to add air to the pipe shall have a blow-off valve set at 5 psig to ensure that at no time the internal pressure in the pipe exceeds 5 psig. The internal pressure of 4 psig shall be maintained for at least two minutes to

allow the air temperature to stabilize, after which the air supply shall be disconnected and the pressure allowed to decrease to 3.5 psig. The time in minutes that is required for the internal air pressure to drop from 3.5 psig to 2.5 psig shall be measured, the results compared with the minimum permissible pressure holding times for runs of single pipe diameter, and for systems of 4- and 6-inch laterals in combination with trunk lines are indicated in the following tables in seconds.

If the pressure drop from 3.5 psig to 2.5 psig occurs in less time than the above-tabulated or calculated values, the pipe shall be overhauled and, if necessary, replaced and relaid until the joints and pipe shall hold satisfactorily under this test.

- (2) Test for Infiltration. If in the construction of a section of the sewer between structures groundwater is encountered, the end of the sewer at the upper structure shall be closed sufficiently to prevent the entrance of water and pumping of groundwater shall be discontinued for at least three days, after which the section shall be tested for infiltration. The infiltration shall not exceed 0.025 gpm per inch of diameter per 1,000 feet of main line sewer being tested not including the length of house laterals entering that section. Where any infiltration in excess of this amount is discovered before completion and acceptance of the sewer, the sewer shall be immediately uncovered and the amount of infiltration reduced to a quantity within the specified amount of infiltration, before the sewer is accepted, at the expense of the Contractor. Should, however, the infiltration be less than the specified amount, the Contractor shall stop any individual leaks that may be observed when ordered to do so by the District Inspector. All tests must be completed before the street or trench is resurfaced, unless otherwise determined by the District Inspector.

NOV. AGE TEST TABLE

MINIMUM HOLDING TIME IN SECONDS REQUIRED FOR PRESSURE TO DROP FROM 14 TO 14 PSIG

		PIPE DIAMETER														
		4"	6"	8"	10"	12"	14"	16"	18"	20"	24"	27"	30"	33"	36"	39"
LENGTH OF LINE IN FEET	25	4	10	18	28	40	62	89	121	158	200	248	299	356	418	
	50	9	20	35	55	79	124	178	243	317	401	495	599	713	837	
	75	13	30	53	83	119	186	257	364	475	601	743	898	1070	1105	
	100	18	40	70	110	158	248	356	485	634	785	951	935			
	125	22	50	88	138	198	309	446	595	680						
	150	26	59	106	165	238	371	510								
	175	31	69	123	193	277	425									
	200	35	79	141	220	317										
	225	40	89	158	248	340										
	250	44	99	176	275											
	275	48	109	194	283											
	300	53	118	211												
	350	62	139	237												
	400	70	156													
	450	79	170													
	500	88														
550	97															
600	106															
650	113	170	227	283	340	425	510	595	680	765	851	935	1020	1105		

NOTES TO BE USED WHEN TESTING ONE DIAMETER ONLY

		LENGTH OF MAIN LINE IN FEET											6" DIAMETER		
		25	50	75	100	125	150	175	200	225	250	275	300	400	500
LENGTH OF LATERAL IN FEET 4" DIAMETER	25	14	24	34	44	54	64	74	84	94	103	113	123	163	168
	50	19	29	39	48	58	68	78	88	98	108	118	128	166	167
	75	23	33	43	53	63	73	83	92	102	112	122	132	164	165
	100	28	37	47	57	67	77	87	97	107	117	127	136	162	163
	125	32	42	52	62	72	81	91	101	111	121	131	141	160	162
	150	36	46	56	66	76	86	96	106	116	125	135	145	159	161
	175	41	51	61	70	80	90	100	110	120	130	140	150	157	159
	200	45	55	65	75	85	95	105	114	124	134	144	153	156	158
	225	50	59	69	79	89	99	109	119	129	139	149	151	154	157
	250	54	64	74	84	94	103	113	123	133	143	149	150	153	156
	275	58	68	78	88	98	108	118	128	138	146	147	149	152	153
	300	63	73	83	92	102	112	122	132	142	145	146	147	151	154
	350	72	81	91	101	111	121	131	140	141	143	144	145	149	152
	400	80	90	100	110	120	130	136	138	139	141	142	143	147	150
	450	89	99	109	119	129	132	134	136	138	139	141	142	145	149
	500	98	108	118	126	129	131	133	135	136	138	139	140	144	147

		LENGTH OF MAIN LINE IN FEET											8" DIAMETER		
		25	50	75	100	125	150	175	200	225	250	275	300	400	500
LENGTH OF LATERAL IN FEET 4" DIAMETER	25	22	40	57	75	92	110	128	145	163	180	198	216	223	224
	50	26	46	62	79	97	114	132	150	167	185	202	218	220	221
	75	31	48	66	84	101	119	136	154	172	189	207	214	217	219
	100	35	53	70	88	106	123	141	158	176	194	209	211	214	216
	125	40	57	75	92	110	128	145	163	180	198	206	207	211	214
	150	44	62	79	97	114	132	150	167	185	201	202	204	209	212
	175	48	66	84	101	119	136	154	172	189	197	199	201	206	210
	200	53	70	88	106	123	141	158	176	192	194	197	199	204	208
	225	57	75	92	110	128	145	163	180	189	192	194	196	202	206
	250	62	79	97	114	132	150	167	183	186	189	191	193	200	204
	275	66	84	101	119	136	154	172	181	184	187	189	191	198	202
	300	70	88	106	123	141	158	174	178	181	184	187	189	196	200
	350	79	97	114	132	150	166	170	174	177	180	183	185	192	197
	400	88	106	123	141	157	162	166	170	174	176	179	181	189	194
	450	97	114	132	148	154	159	163	167	170	173	176	178	186	191
	500	106	123	140	146	151	156	160	164	167	170	173	175	183	189

LENGTH OF LATERAL IN FEET 6" DIAMETER	LENGTH OF MAIN LINE IN FEET											8" DIAMETER		
	25	50	75	100	125	150	175	200	225	250	275	300	400	500
25	28	45	63	80	98	116	133	151	168	186	204	221	224	225
50	37	55	73	90	108	126	143	161	178	196	214	220	222	223
75	47	65	83	100	118	135	153	171	188	206	217	217	220	221
100	57	75	93	110	128	145	163	181	198	214	214	215	218	220
125	67	85	102	120	138	155	173	190	208	211	212	213	216	218
150	77	95	112	130	148	165	182	200	207	209	210	211	214	217
175	87	105	122	140	157	175	192	204	206	207	208	209	213	215
200	97	114	132	150	167	185	201	202	204	205	206	207	211	214
225	107	124	142	160	177	195	199	201	203	204	205	206	210	213
250	117	134	152	169	187	195	198	199	201	202	203	204	209	212
275	127	144	162	179	192	194	196	198	200	201	202	204	208	210
300	136	154	172	187	190	192	195	196	198	200	201	202	207	209
350	156	174	181	185	187	190	193	194	196	198	199	200	205	208
400	173	178	181	184	186	189	191	192	194	196	197	198	203	206
450	173	177	180	183	185	187	189	190	192	194	195	196	201	204
500	173	177	180	182	184	186	188	189	191	192	193	194	200	203

LENGTH OF LATERAL IN FEET 6" DIAMETER	LENGTH OF MAIN LINE IN FEET											10" DIAMETER		
	25	50	75	100	125	150	175	200	225	250	275	300	400	500
25	32	59	87	114	142	169	197	224	252	277	277	278	279	280
50	36	64	91	119	146	174	201	229	256	271	272	273	275	277
75	41	68	96	123	151	178	206	233	261	265	267	268	272	274
100	45	73	100	128	155	183	210	238	258	260	262	264	268	271
125	50	77	105	132	160	187	214	242	253	255	257	259	264	268
150	54	81	109	136	164	191	219	244	248	251	253	255	261	265
175	58	86	113	141	168	196	223	239	243	246	249	251	258	262
200	63	90	118	145	173	200	228	235	239	242	245	248	255	260
225	67	95	122	150	177	205	228	231	235	239	242	244	252	257
250	72	99	127	154	182	209	222	227	231	235	238	241	249	255
275	76	103	131	158	186	211	218	223	228	231	235	238	247	253
300	80	108	135	163	190	208	214	220	224	228	232	235	244	250
350	89	117	144	172	194	201	208	213	218	222	226	229	239	246
400	98	125	153	179	188	196	202	208	213	217	221	224	235	242
450	107	134	162	174	183	191	197	203	208	212	216	220	230	238
500	116	143	160	170	179	186	193	198	203	208	212	215	225	235

LENGTH OF LATERAL IN FEET 6" DIAMETER	LENGTH OF MAIN LINE IN FEET											10" DIAMETER		
	25	50	75	100	125	150	175	200	225	250	275	300	400	500
25	37	65	92	120	147	175	202	230	257	277	278	278	279	280
50	47	75	102	130	157	185	212	240	267	271	272	273	276	277
75	57	85	112	140	167	195	222	250	265	266	267	269	272	274
100	67	95	122	150	177	205	232	257	260	262	263	265	269	271
125	77	105	132	160	187	215	242	253	255	257	259	261	266	269
150	87	114	142	169	197	224	245	248	251	254	256	257	263	266
175	97	124	152	179	207	234	241	245	248	250	252	254	260	264
200	107	134	162	189	217	233	237	241	244	247	249	251	258	262
225	117	144	172	199	225	230	234	238	241	244	246	248	255	260
250	127	154	182	209	222	227	231	235	238	241	243	246	253	258
275	136	164	191	213	219	224	229	232	236	238	241	243	251	256
300	146	174	201	211	217	222	226	230	233	236	239	241	249	254
350	166	192	200	207	212	217	222	226	229	232	235	237	245	250
400	181	190	197	203	209	214	218	222	225	228	231	233	241	247
450	180	188	195	201	206	211	215	218	222	225	227	230	238	244
500	179	186	193	198	203	208	212	215	219	222	224	227	235	241

		LENGTH OF MAIN LINE IN FEET											12" DIAMETER		
		25	50	75	100	125	150	175	200	225	250	275	300	400	500
LENGTH OF LATERAL IN FEET 4" DIAMETER	25	44	84	123	163	202	242	282	321	332	333	334	334	336	336
	50	48	88	128	167	207	246	296	321	324	326	327	328	331	333
	75	53	92	132	172	211	251	290	316	317	319	321	323	327	329
	100	57	97	136	176	216	255	295	308	311	313	316	317	323	326
	125	62	101	141	180	220	260	297	301	304	308	310	312	319	323
	150	66	106	145	185	224	264	290	295	299	302	305	308	315	319
	175	70	110	150	189	229	268	283	289	293	297	300	303	311	316
	200	75	114	154	194	233	271	277	283	288	292	296	299	308	313
	225	79	119	158	198	238	265	272	278	283	288	291	295	304	310
	250	84	123	163	202	242	259	267	273	278	283	287	291	301	308
	275	88	128	167	207	244	254	262	269	274	279	283	287	298	305
	300	92	132	172	211	239	249	257	264	270	275	279	283	295	302
	350	101	141	180	218	231	241	249	256	262	268	272	276	289	297
	400	110	150	189	210	223	233	242	249	255	261	266	270	283	292
	450	119	158	189	204	216	227	235	243	249	255	260	264	278	288
500	128	166	184	198	210	221	229	237	243	249	254	259	273	283	

		LENGTH OF MAIN LINE IN FEET											12" DIAMETER		
		25	50	75	100	125	150	175	200	225	250	275	300	400	500
LENGTH OF LATERAL IN FEET 6" DIAMETER	25	50	89	129	168	208	248	287	327	331	332	333	333	335	336
	50	59	99	139	178	218	257	297	321	323	325	326	327	330	332
	75	69	109	149	188	228	267	307	314	316	318	320	321	326	328
	100	79	119	158	198	238	277	302	306	309	312	314	316	321	325
	125	89	129	168	208	248	287	295	300	303	306	309	311	317	321
	150	99	139	178	218	257	284	289	294	298	301	304	306	314	318
	175	109	149	188	228	267	278	284	289	293	296	299	302	310	315
	200	119	158	198	238	265	272	278	284	288	292	295	298	306	312
	225	129	168	208	248	260	268	274	279	284	288	291	294	303	309
	250	139	178	218	246	255	263	269	275	280	284	287	290	300	306
	275	149	188	228	242	251	259	266	271	276	280	284	287	297	304
	300	158	198	227	238	248	255	262	268	272	277	281	284	294	301
	350	178	208	221	232	241	249	255	261	266	271	274	278	289	296
	400	189	204	217	227	236	243	250	256	261	265	269	273	284	292
	450	187	201	213	223	231	239	245	251	256	260	264	268	279	288
500	186	199	210	219	227	234	240	246	251	256	260	263	275	284	

109-1.3

Type Tests for Plastic Sewer Pipe - The following tests shall be applied to plastic sewer pipe:

- (1) Air Testing. The duration permitted for a prescribed low pressure air exfiltration pressure drop between two consecutive manholes shall be not less than that shown below. The prescribed drop shall not exceed 0.5 psi from 3.5 to 3.0 psi in excess of the groundwater pressure above the top of the sewer.

MINIMUM DURATION FOR AIR  
TEST PRESSURE DROP

<u>Pipe Size (inches)</u>	<u>Time (minutes)</u>
4	2-1/2
6	4
8	5
10	6-1/2
12	7-1/2
15	9-1/2

- (2) Infiltration Testing. Infiltration testing shall be an acceptable method of leakage test only when the groundwater level is above the top of the pipe throughout the length being tested. The allowable infiltration for any portion of sewer system shall be measured by a weir or current meter placed in the appropriate manhole and shall not exceed 50 gallons per inch of internal pipe diameter per mile per day.
- (3) Exfiltration Testing. Exfiltration testing is an acceptable method of test only in dry areas or when the groundwater level above the pipe is suitably low. The allowable water exfiltration for any length of sewer pipe between manholes shall be measured and shall not exceed 50 gallons per inch of internal pipe diameter per mile of pipe per day. During exfiltration testing, the maximum internal pipe pressure at the lowest end shall not exceed 25 feet of water or 10.8 psi and the internal water head shall be 2 feet higher than the top of the pipe or 2 feet higher than the groundwater level, whichever is greater.

109-1.4

Manhole Test - Watertightness of manholes may be tested in connection with tests of sanitary sewers or at the time the manhole is completed and backfilled. The Contractor shall plug all inlets and outlets with approved stoppers or plugs and fill the manhole to the limits indicated below. Any evidence of leakage as a result of testing shall be repaired to the satisfaction of the District Inspector.



The manhole shall be filled with water to 1 foot below the start of the cone section with a minimum depth of 4 feet and a maximum depth of 20 feet.

The water shall stand in the manhole for a minimum of one hour to allow the manhole material to reach maximum absorption. After the one-hour period has elapsed, the Contractor shall refill the manhole to the original depth and the drop in water surface shall be recorded after a period of from 15 minutes to one hour has elapsed, time of the test being determined by the District Inspector and varied by the District Inspector to fit the various field conditions.

The maximum allowable drop in the water surface shall be 1/2 inch for each 15-minute period of testing. Even though the leakage is less than the specified amount, the Contractor shall stop any leaks that may be observed to the satisfaction of the District Inspector.

109-1.5

Test for Damaged or Defective V.C.P. in Place - After the pipe has been installed and tested, and the compacted backfill placed, but after manholes are raised to grade and resurfacing is completed, the pipe shall be balled from manhole to manhole with a sewer scrubbing ball of a type and size to be approved by the District Inspector. In addition to and after balling the pipe, all straight sewers and inlet and outlet ends of curvilinear sewers shall be mirrored by the District Inspector with the assistance of the Contractor's forces. All balling and mirroring shall be done in the presence of the District Inspector and shall constitute tests for alignment, grade, damage, or defective pipe in place, or any other type of faulty installation. Should balling and mirroring indicate any faulty installation of the pipe, repairs or replacements shall be made by the Contractor as directed by the District Inspector.

109-1.6

Test for Damaged or Defective Plastic Sewer Pipe in Place - Following the placement and densification of backfill and prior to the placing of permanent pavement, all main line pipe shall be cleaned and then mandrelled to measure for obstructions (deflections, joint offsets, and lateral pipe intrusions). A rigid mandrel shall be pulled through the pipe by hand. The mandrel shall have a cross section equivalent to a circle having a diameter of at least 95% of the specified average inside diameter for PVC and ABS solid wall pipe and 96% for ABS composite pipe. The minimum length of the circular portion of the mandrel shall be equal to the nominal diameter of the pipe.

Obstructions encountered by the mandrel shall be corrected by the Contractor.

All material, equipment, and labor to perform the test shall be provided by the Contractor at no cost to the District.

INDEX

STANDARD DETAIL DRAWINGS

S-1	Standard Manhole Details
S-2	Standard 60-Inch Manhole
S-3	Saddle & Cut in Wye Connection
S-4	Pipe Casing, Concrete Encasement, & House Lateral
S-5	Pipe Bedding Details
S-6	Plastic Pipe Details
S-7	Separation of Sewers for Water and Reclaimed Water Lines
S-8	Standard Sewer Notes Sheet 1
S-9	Standard Sewer Notes Sheet 2
S-10	Check List for Developers

WHEN BROKEN END OF PIPE IS WITHIN MANHOLE, BREAK BACK FLUSH WITH INSIDE OF MANHOLE WALL AND PLASTER BROKEN EDGES SMOOTH. WHEN UNBROKEN END OF PIPE IS IN MANHOLE, LEAVE SQUARE END AND FILL FILLETS AT UPPER SECTION TO DRAIN.

THE CROWN ELEVATION OF ALL PIPES SHALL BE THE SAME AS THE CROWN ELEVATION OF THE LARGEST PIPE UNLESS OTHERWISE INDICATED.

MANHOLE SHAFT OPENING TO BE PLACED ON UPSTREAM SIDE OF MANHOLE. LADDER RUNGS ARE NOT PERMITTED.

MANHOLE FRAME AND COVER SHALL BE M-1254 OR M-1252 AS MANUFACTURED BY MORITZ FOUNDRY CO., SANTA ANA, CALIFORNIA, OR APPROVED EQUAL.

DETAILS ARE TYPICAL OF FRAME AND COVER FOR 48" AND 60" MANHOLES.

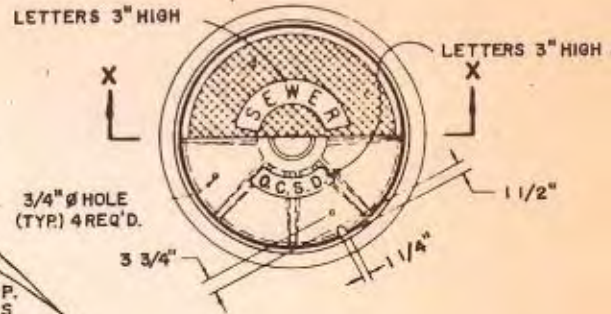
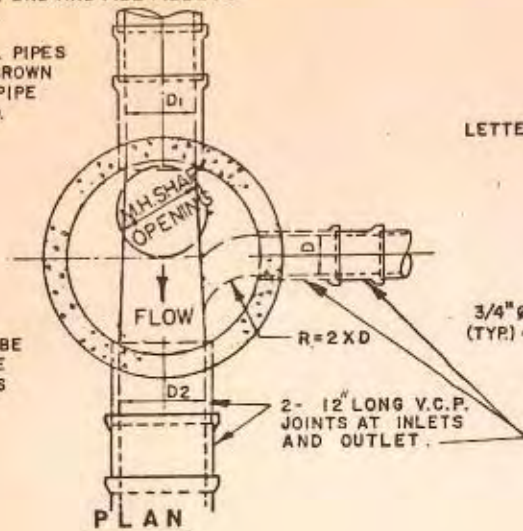

PLAN



SECTION X-X

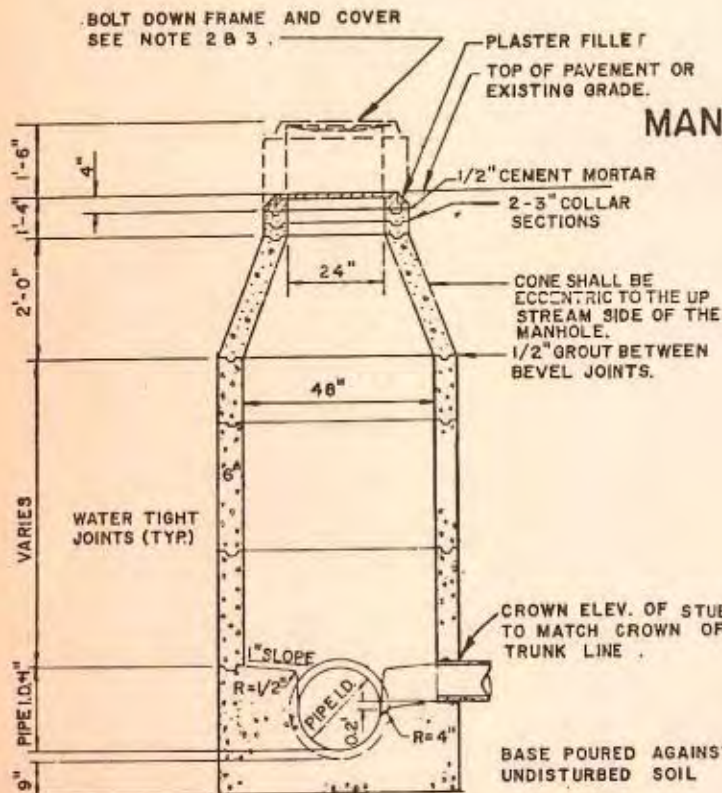

MANHOLE FRAME AND COVER

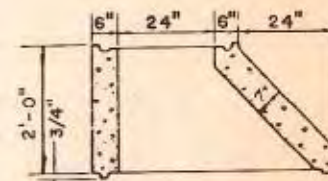

CONE DETAIL

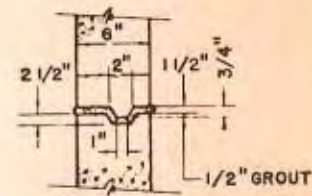

JOINT DETAIL

STANDARD 48" MANHOLE

NOTES:

1. 48" I.D. MANHOLE TO BE USED ON SEWERS 24" IN DIA. AND UNDER WHERE COVER DEPTH IS 6' TO 12'.
2. M.H. FRAME AND COVER TO BE RAISED 18" ABOVE NATURAL GROUND WHEN LOCATED OUTSIDE OF IMPROVED AREA, OR 0.10' ABOVE EXISTING GRADE WHEN LOCATED WITHIN ROADWAY SHOULDER.
3. M.H. IN EASEMENTS TO HAVE BOLT DOWN FRAME AND COVER, AHAMBRA A-1252 B, A-1254 B OR EQUAL.

LOS ALAMITOS COUNTY WATER DISTRICT  
ORANGE COUNTY, CALIFORNIA

STANDARD MANHOLE DETAILS

1973

BOYLE ENGINEERING

S-1

CUT PIPE FLUSH WITH INSIDE OF MANHOLE. BROKEN EDGES SHALL BE PLASTERED WITH A CEMENT MORTAR TO GIVE A SMOOTH ENTRANCE TO THE PIPE. THE CROWN ELEVATION OF ALL PIPES SHALL BE THE SAME AS THE CROWN ELEVATION OF THE LARGEST PIPE UNLESS OTHERWISE INDICATED.

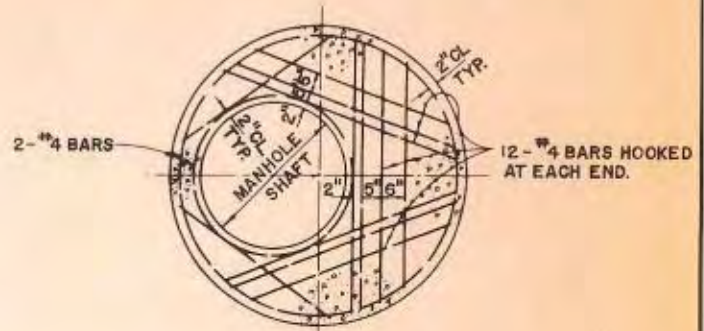
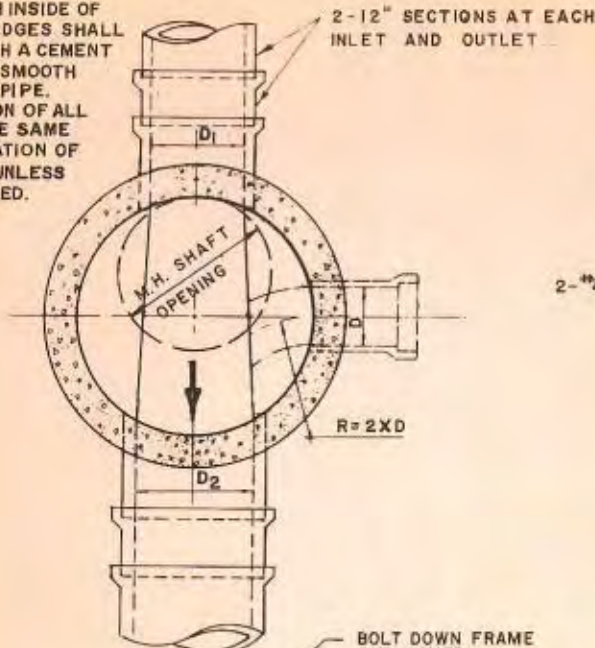

**ECCENTRIC FLAT TOP**

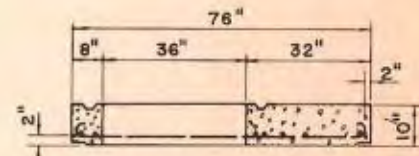

**ECCENTRIC FLAT TOP DETAIL**

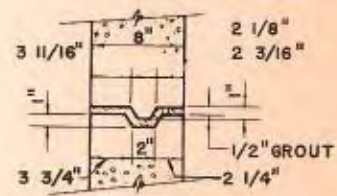

**JOINT DETAIL**

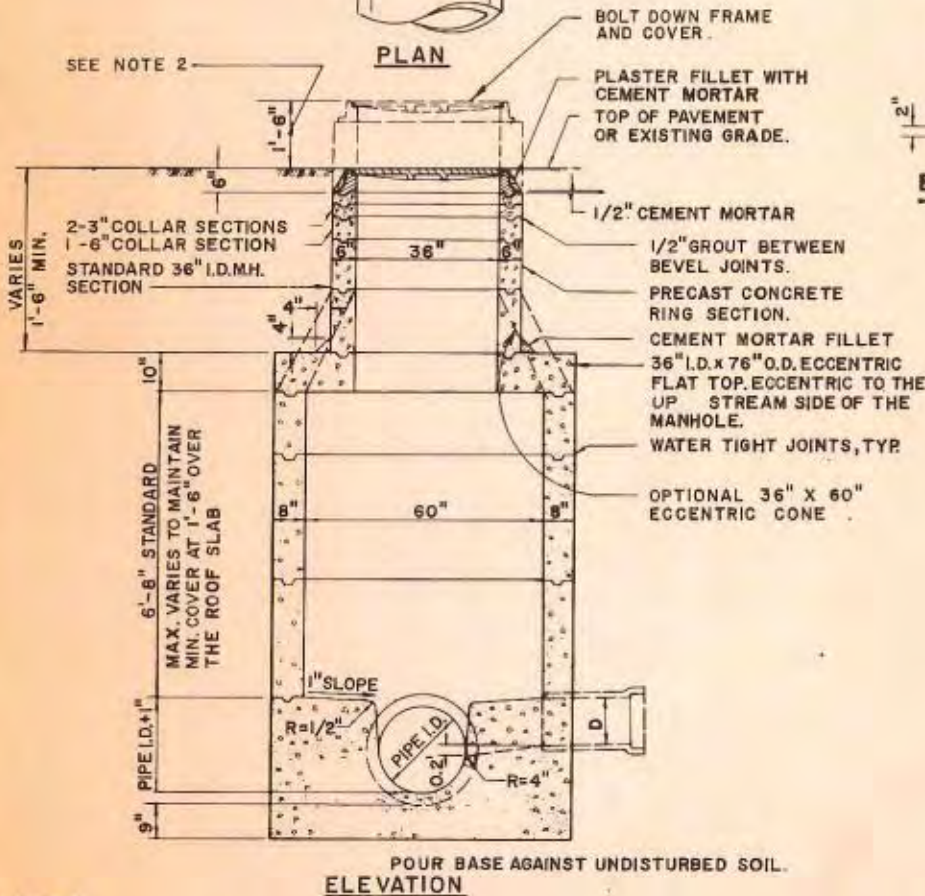

**ELEVATION**

**NOTES:**

1. THE 60" MANHOLE SHALL BE USED ON SEWERS 27" IN DIAMETER AND LARGER OR OTHER SPECIAL CASES AND WHEN COVER DEPTH IS BETWEEN 12' & 18'.
2. M.H. FRAME AND COVER TO BE RAISED 18" ABOVE NATURAL GROUND WHEN LOCATED OUTSIDE OF IMPROVED AREA, OR 0.10' ABOVE EXISTING GRADE WHEN LOCATED WITHIN ROADWAY SHOULDER.
3. FOR FRAME AND COVER DETAILS REFER TO THE STANDARD MANHOLE DETAILS.

LOS ALAMITOS COUNTY WATER DISTRICT  
ORANGE COUNTY, CALIFORNIA

**STANDARD 60 INCH MANHOLE**

REVISED OCT. 1980

MAY 1963

BOYLE ENGINEERING

S-2

THE BELL ON THE COLLAR WYE SADDLE SHALL NOT BE ENCASED IN CONCRETE.

TAP TO BE MADE AT APPROX.  $\frac{1}{4}$  OF JOINT. ENCASE 12" EACH SIDE OF OPENING WITH CLASS "A" CONCRETE.

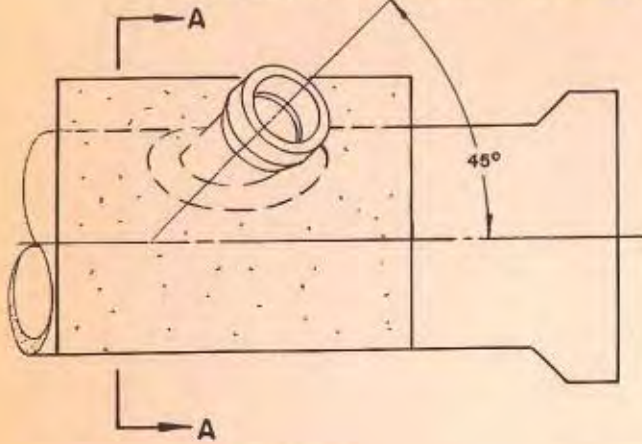

ELEVATION

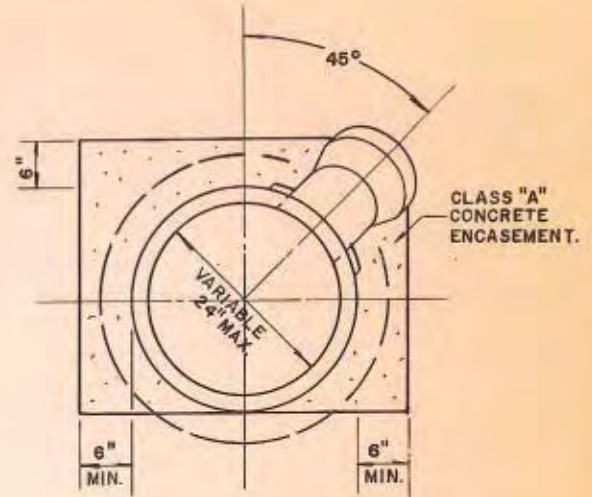

SECTION A - A

SADDLE CONNECTION

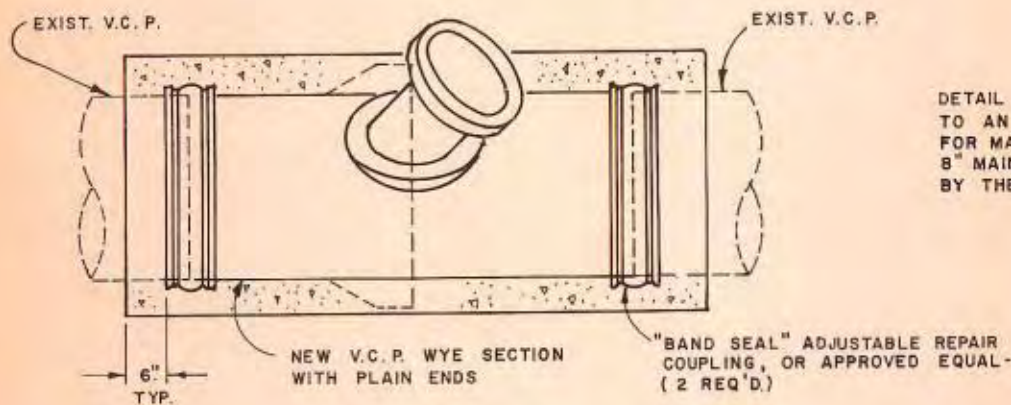

DETAIL MAKING CONNECTION TO AN EXISTING SEWER: FOR MAKING 6" LATERAL ON 8" MAIN OR AS REQUIRED BY THE DISTRICT.

CUT IN WYE CONNECTION

NOTES:

1. THE SEWER LINE SHALL BE SCORED TO THE APPROXIMATE SHAPE OF THE COLLAR WYE OR TEE FITTING. THE CONTRACTOR SHALL EITHER CUT A NEAT OPENING WITH A CIRCULAR CERAMIC SAW OF 2", 4", 6", OR 8" DIAMETERS; OR MAKE A SMALL HOLE, NOT LARGER THAN ONE-INCH IN DIAMETER, IN THE APPROXIMATE CENTER OF THE SCORED AREA WITH A POINTED TOOL, SIMILAR TO A MASON'S PICK, AND CHIP WITH A SHORT HANDLE, HAND HELD HAMMER IN A SPIRAL FASHION TO THE SCORED LINE.
2. THE CONTRACTOR SHALL SECURE THE COLLAR WYE SADDLE TO THE SEWER WITH EPI BOND157, AN EPOXY RESIN AS MANUFACTURED BY FURANE PLASTICS INC. 4516 BRAZIL ST. LOS ANGELES, OR APPROVED EQUAL.
3. THE CONTRACTOR SHALL ENCASE THE SADDLE CONNECTION WITH CLASS "A" CONCRETE AFTER THE CONNECTION IS APPROVED BY THE DISTRICT TO THE LIMITS INDICATED ABOVE.
4. THE CONTRACTOR SHALL KEEP ALL CLAY CHIPS, DIRT, EPOXY, MORTAR, AND CONCRETE OUT OF THE SEWER SADDLED, AND SHALL PERFORM A CLEANING AND BALLING OF THE REACH SADDLED IF DIRECTED TO DO SO BY THE DISTRICT.
5. THE CONTRACTOR SHALL REPAIR OR REPLACE ANY DAMAGED PIPE AS DIRECTED BY THE DISTRICT.

LOS ALAMITOS COUNTY WATER DISTRICT  
ORANGE COUNTY, CALIFORNIA

**SADDLE & CUT IN WYE CONNECTION**

MAY  
1963

BOYLE ENGINEERING

S-3

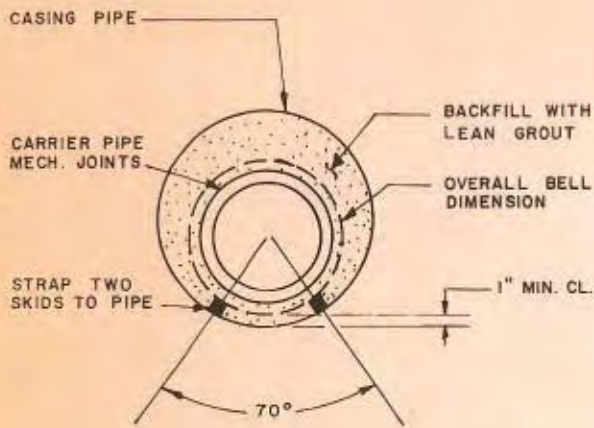

CARRIER PIPE SHALL BE ANCHORED AND/OR WEIGHED BEFORE GROUTING TO AVOID FLOATING.

TYPICAL PIPE CASING

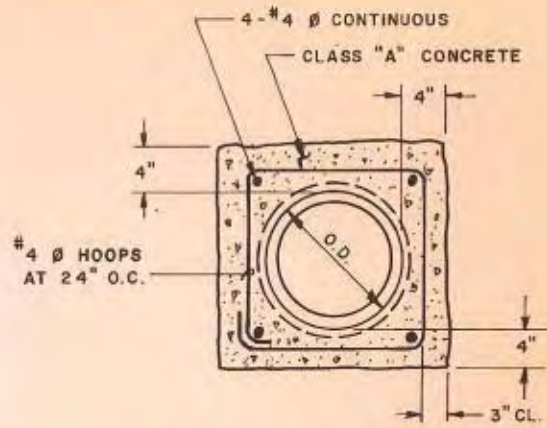

CONCRETE ENCASUREMENT SHALL BE EXTENDED TO 3" FROM BELL AND A ONE FOOT SECTION OF PIPE SHALL BE USED BEFORE AND AFTER THE ENCASUREMENT.

REINFORCED CONCRETE ENCASUREMENT

WHERE V.C.P WYE IS IN INSTALLED WITHOUT HOUSE LATERAL, THE WYE SHALL BE PLUGGED WITH A V.C. PLUG OR NEOPRENE STOPPER.

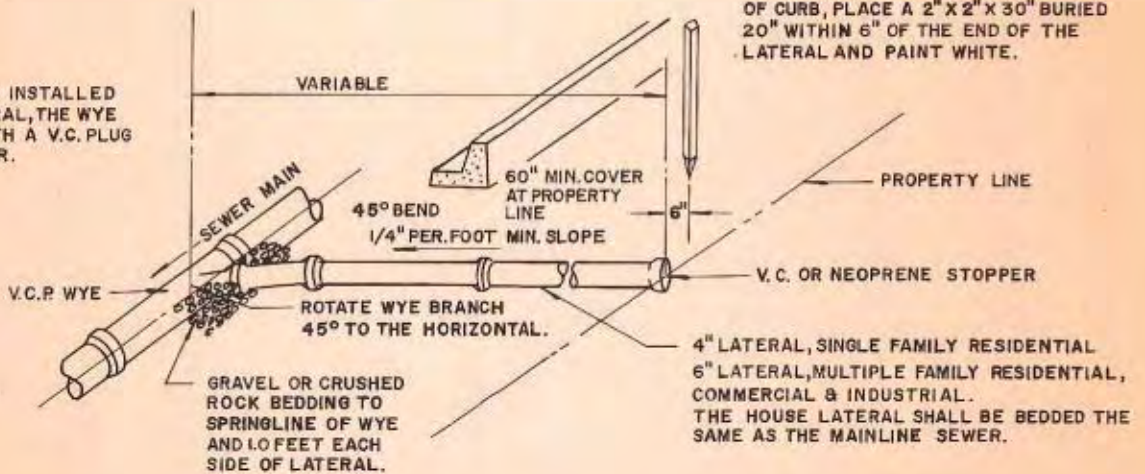

TYPICAL HOUSE LATERAL

LOS ALAMITOS COUNTY WATER DISTRICT  
ORANGE COUNTY, CALIFORNIA

PIPE CASING, CONCRETE ENCASUREMENT  
& HOUSE LATERAL

MAY  
1963

BOYLE ENGINEERING

S - 4

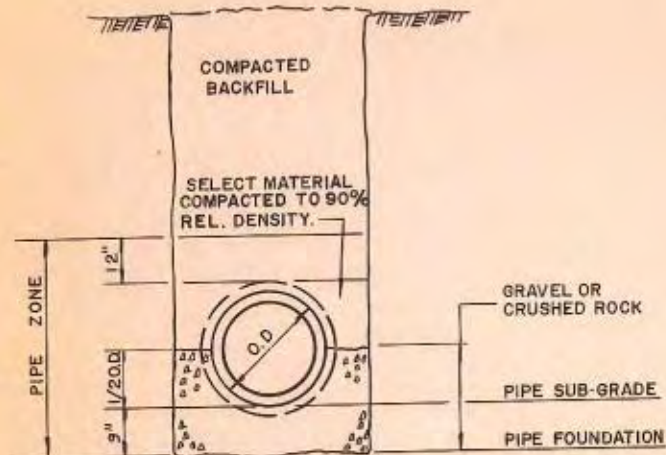

TYPE I

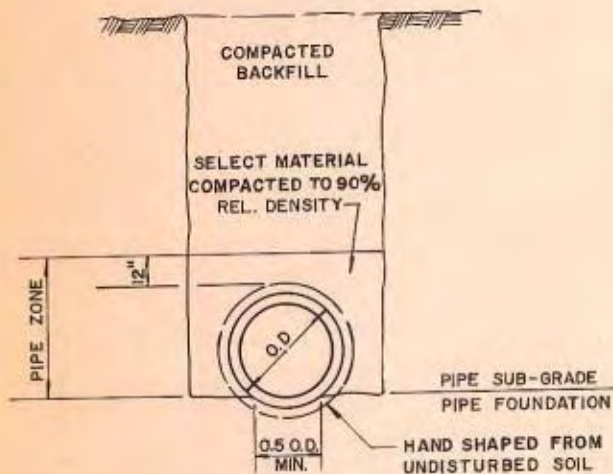

TYPE III

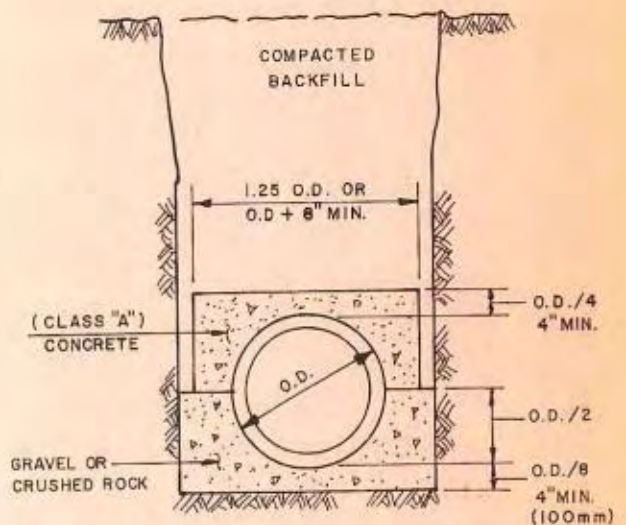

TYPE IV

NOTES:

1. THE TRENCH WIDTH AT THE UPPER LIMIT OF THE PIPE ZONE SHALL BE WITHIN THE FOLLOWING LIMITS FOR TYPE I, AND III BEDDING:  
 MAXIMUM TRENCH WIDTH - O.D. OF PIPE OR BELL PLUS 16"  
 MINIMUM TRENCH WIDTH - O.D. OF PIPE OR BELL PLUS 12"
2. TYPE IV BEDDING SHALL BE USED WHERE THE TRENCH WIDTH AT THE UPPER LIMIT OF THE PIPE ZONE EXCEEDS THE MAXIMUM WIDTH SPECIFIED ABOVE.
3. BACKFILL ABOVE THE PIPE ZONE SHALL CONFORM TO THE REQUIREMENTS OUTLINED IN SECTION 100 OF THE STANDARD SPECIFICATIONS.

LOS ALAMITOS COUNTY WATER DISTRICT  
 ORANGE COUNTY, CALIFORNIA

**PIPE BEDDING DETAILS**

MAY  
 1963

**BOYLE ENGINEERING**

S - 5

NOTE: PLASTIC SEWER PIPE  
MAY BE USED ONLY  
WITH WRITTEN CONSENT  
OF THE DISTRICT  
ENGINEER

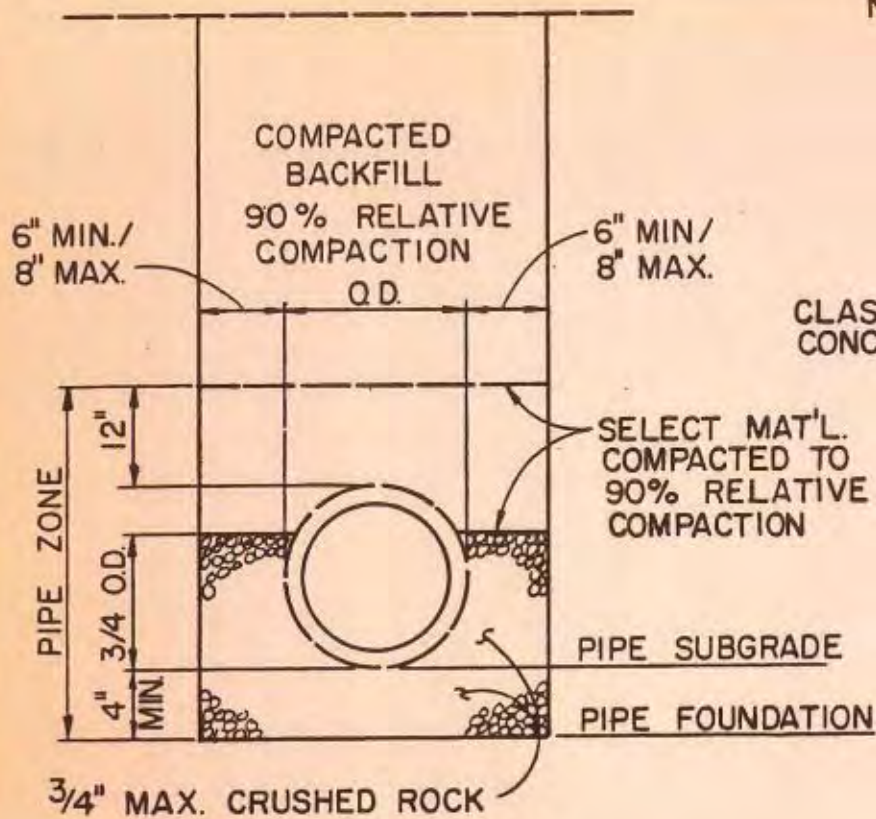

**NORMAL BEDDING**

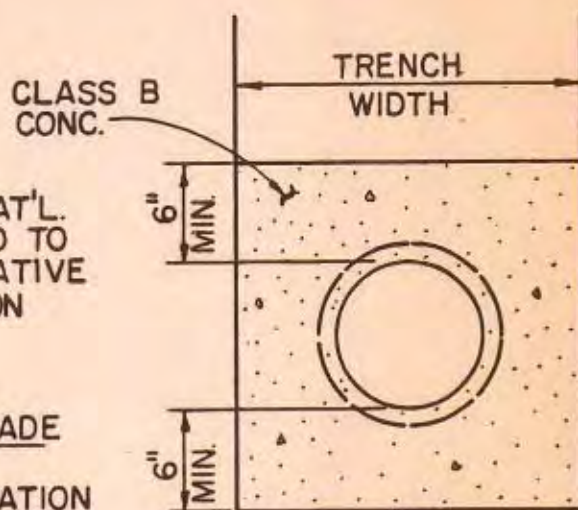

**CONCRETE ENCASEMENT**

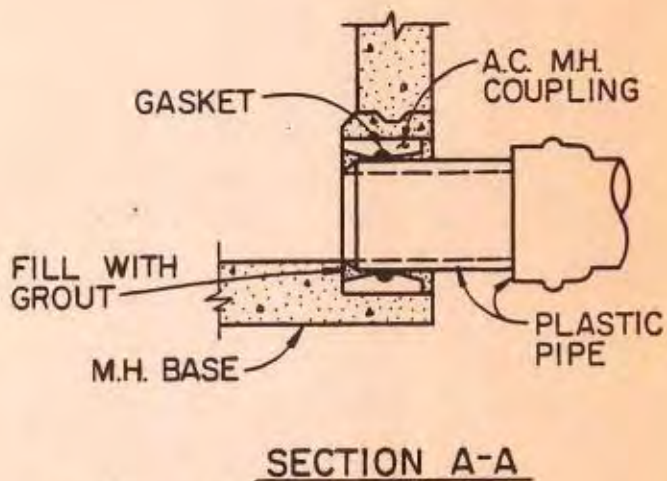
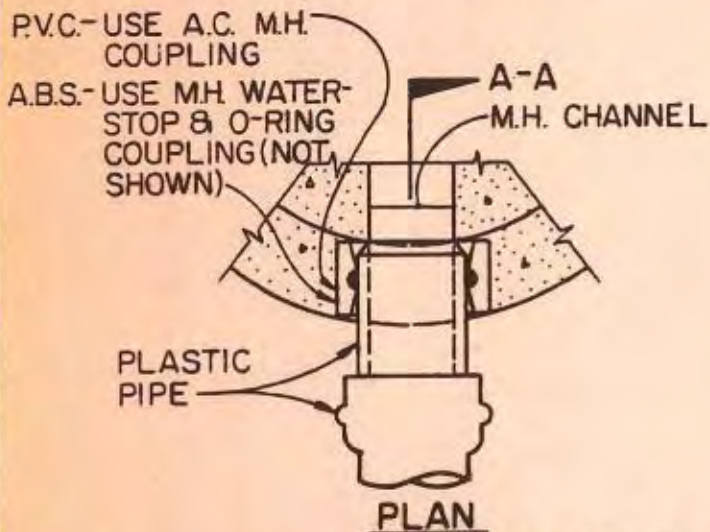

**MANHOLE CONNECTION DETAILS**

**NOTES:**

1. NORMAL BEDDING SHALL BE USED FOR DEPTH OF COVER  $>4'$  OR  $\leq 17'$  FOR P.V.C. AND  $>4'$  OR  $\leq 20'$  FOR A.B.S. COMPOSITE AND SOLID WALL. BEDDING FOR DEPTH OF COVER  $>4'$  OR  $< 17'$  (20 FOR A.B.S. PIPE) TO BE DETERMINED BY THE DISTRICT.
2. CONCRETE ENCASEMENT SHALL BE USED WHERE THE TRENCH WIDTH AT THE UPPER LIMITS OF THE PIPE ZONE EXCEEDS THE MAX. WIDTH SPECIFIED ABOVE.
3. IN LIEU OF THE MATERIAL FROM THE BEDDING TO THE TOP OF THE PIPE ZONE, THE CONTRACTOR MAY EXTEND THE BEDDING TO THE TOP OF THE PIPE ZONE.
4. SEE STD. DWGS. S-1 AND S-2 FOR MANHOLE DETAILS.

LOS ALAMITOS COUNTY WATER DISTRICT  
ORANGE COUNTY, CALIFORNIA

**PLASTIC PIPE DETAILS**

REVISED 10 - 1980

1973

*Boyle Engineering Corporation*

S - 6



DESIGN REQUIREMENTS FOR SANITARY SEWERS IN THE VICINITY OF PRESSURE WATER OR RECLAIMED WATER MAINS

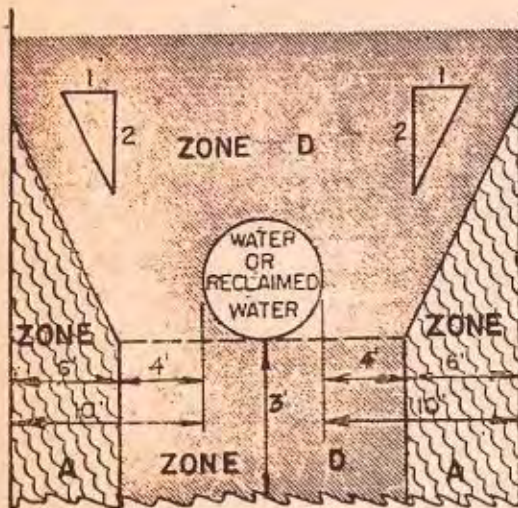

PARALLEL CONST.

IF A SANITARY SEWER IS TO BE LOCATED WITHIN 10 FEET OF A PRESSURE WATER MAIN OR RECLAIMED WATER MAIN WITHIN ANY OF THE ABOVE INDICATED ZONES, SPECIAL CONSTRUCTION WILL BE REQUIRED AS SHOWN BELOW.

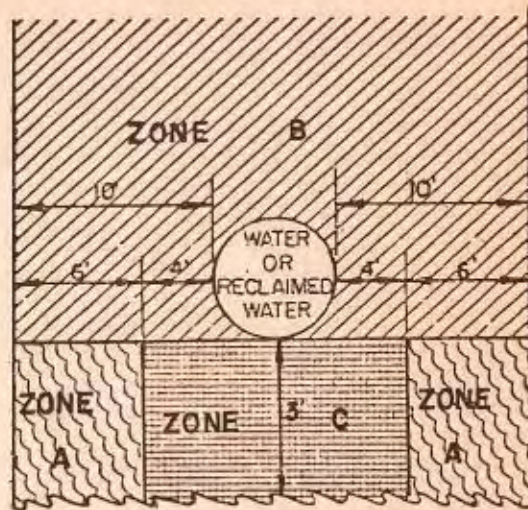

PERPENDICULAR CONST.

IF A MAIN LINE SEWER MUST CROSS A PRESSURE WATER MAIN OR RECLAIMED WATER MAIN WITHIN ANY OF THE ABOVE INDICATED ZONES, OR IF A HOUSE LATERAL MUST CROSS IN ZONE B, SPECIAL CONSTRUCTION WILL BE REQUIRED AS SHOWN BELOW.

ZONE	SEWER CONSTRUCTION REQUIREMENTS
A	V.C.P. WITH COMPRESSION JOINTS.
B OR C	C.I.P. (CLASS 150) APPROVED MECHANICAL JOINTS; OR V.C.P. WITH SPECIAL CONCRETE ENCASEMENT PER (DETAIL 1); OR V.C.P. GROUTED IN CONTINUOUS STEEL CASING.
D	DO NOT LOCATE ANY PARALLEL SEWER IN THIS AREA WITHOUT WATER DIST. AND HEALTH DEPARTMENT APPROVAL.

GENERAL NOTES

1. EXTEND BOTH ENDS OF ENCASEMENT TO A POINT ONE INCH SHORT OF FIRST PIPE JOINT BEYOND LOCATIONS SPECIFIED ON PLAN. USE ONE FOOT SECTION OF PIPE AT BOTH ENDS BEFORE USING STANDARD LENGTHS.
2. APPLY FORM OIL, THIN PLASTIC SHEET, OR OTHER ACCEPTABLE MATERIAL TO PIPE, TO PREVENT BOND BETWEEN PIPE AND CONCRETE.
3. USE CLASS "A" CONCRETE FOR ALL CASES.
4. PLASTIC SEWER PIPE MAY BE USED IN PLACE OF V.C.P. WITH DISTRICT APPROVAL ON THE IMPROVEMENT PLANS.

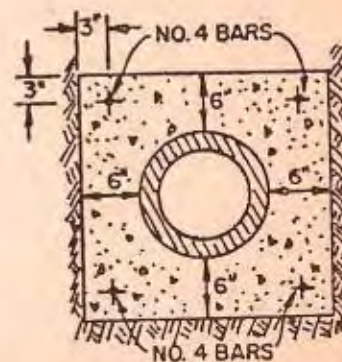

SPECIAL ENCASEMENT DETAIL 1

LOS ALAMITOS COUNTY WATER DISTRICT  
ORANGE COUNTY, CALIFORNIA

SEPARATION OF SEWERS FOR WATER  
AND RECLAIMED WATER LINES

1973

Boyle Engineering Corporation

S-7

SEWER NOTES

1. ALL SANITARY SEWER WORK SHALL CONFORM TO THE "STANDARD SPECIFICATIONS FOR THE CONSTRUCTION OF SANITARY SEWERS" OF THE LOS ALAMITOS COUNTY WATER DISTRICT. THE CONTRACTOR SHALL KEEP A COPY OF THE STANDARD SPECIFICATIONS AND DRAWINGS ON THE JOB SITE AT ALL TIMES.
2. FOUR COPIES OF APPROVED CONSTRUCTION PLANS SHALL BE FURNISHED TO THE DISTRICT ENGINEER'S OFFICE PRIOR TO BEGINNING CONSTRUCTION.
3. THE DISTRICT ENGINEER SHALL BE NOTIFIED AT LEAST TWO WORKING DAYS PRIOR TO ANY INSPECTION. CALL (714) 752-0505.
4. FOUR-INCH, INTERNAL DIAMETER, VCP HOUSE CONNECTIONS ARE TO BE CONSTRUCTED FROM THE SEWER MAIN LINE TO THE PROPERTY LINE FOR EACH LOT OR AS SHOWN ON THE PLANS.
5. ALL SEWER MAINS, HOUSE CONNECTIONS, AND APPURTENANCES SHALL BE CONSTRUCTED PRIOR TO PAVING OF THE STREET.
6. SEWER LENGTHS ARE CALCULATED ON HORIZONTAL DISTANCES.
7. VCP STUBS AND THE FIRST TWO JOINTS OUT OF ALL MANHOLES SHALL BE ONE FOOT MAXIMUM MEASURED FROM THE INSIDE WALL OF THE MANHOLE.
8. THE SURVEYOR SHALL STAKE THE LOCATION OF ALL WYE FITTINGS. ALL HOUSE LATERALS NOT NORMAL TO STREET SEWERS SHALL HAVE END OF LATERAL AT PROPERTY LINE STAKED AND TIED TO A PROPERTY LINE AS SHOWN ON THE PLANS.
9. IT SHALL BE THE RESPONSIBILITY OF THE SEWER CONTRACTOR TO EXPOSE ALL JOINT POINTS TO EXISTING LINES AND TO HAVE THE LOCATION AND ELEVATION VERIFIED BY THE DISTRICT ENGINEER PRIOR TO ANY SEWER STAKES BEING FURNISHED.
10. THE LOS ALAMITOS COUNTY WATER DISTRICT WILL INSPECT ALL MAIN LINE SEWERS. THE CITY OF LOS ALAMITOS WILL INSPECT AND CERTIFY ALL HOUSE LATERALS. A MINIMUM OF 10 FEET 4 INCHES OF HOUSE LATERAL SHALL BE INSTALLED AND INSPECTED BY THE CITY OF LOS ALAMITOS AND TESTED JOINTLY WITH THE MAIN LINE UNDER THE JURISDICTION OF THE LOS ALAMITOS COUNTY WATER DISTRICT.

LOS ALAMITOS COUNTY WATER DISTRICT  
ORANGE COUNTY, CALIFORNIA

STANDARD SEWER NOTES  
SHT. 1 OF 2

1980

BOYLE ENGINEERING

S-8

11. IN ORDER TO PREVENT ACCIDENTAL USE OF THE NEW SEWER PRIOR TO COMPLETION AND ACCEPTANCE, THE INLET OF THE DOWNSTREAM EXISTING MANHOLE SHOULD BE PLUGGED WITH BRICK AND MORTAR.
12. NO FACILITY SHALL BE BACKFILLED UNTIL INSPECTED BY THE LOS ALAMITOS COUNTY WATER DISTRICT.
13. SEWER MAIN OWNERSHIP- UPON COMPLETION OF ALL TESTS AND DEDICATION BY THE DEVELOPER, OPERATION AND MAINTENANCE SHALL BE THE RESPONSIBILITY OF LOS ALAMITOS COUNTY WATER DISTRICT.
14. SEWER LATERAL OWNERSHIP- UPON COMPLETION OF ALL TESTS AND ACCEPTANCE BY THE CITY OF LOS ALAMITOS, OPERATION AND MAINTENANCE SHALL NOT BE THE RESPONSIBILITY OF LOS ALAMITOS COUNTY WATER DISTRICT.
15. PROVIDE A CLEANOUT STUB OUTSIDE OF THE HOUSE OR GARAGE AND IDENTIFY WITH A LANDMARK TO FACILITATE SEWER HOUSE LATERALS AND MAIN LINE CLEANING.
16. ALL SEWER HOUSE LATERALS ARE TO BE LOCATED WITH A LETTER "S" CHISELED IN CURB FACE PER LOS ALAMITOS COUNTY WATER DISTRICT SPECIFICATIONS.

LOS ALAMITOS COUNTY WATER DISTRICT  
ORANGE COUNTY, CALIFORNIA

STANDARD SEWER NOTES  
SHT. 2 OF 2

### DEVELOPER'S CHECK LIST

1. ARRANGE MEETING WITH DISTRICT ENGINEER FOR LOCATION OF DISTRICT FACILITIES.
2. SUBMIT IMPROVEMENT PLANS WITH PRELIMINARY PLAN CHECK FEE AND TENTATIVE EASEMENT DESCRIPTIONS AND SKETCHES (IF REQUIRED) TO DISTRICT ENGINEER.
3. REVISE IMPROVEMENT PLANS AND EASEMENT DESCRIPTIONS AND SKETCHES AS REQUIRED AND RETURN TO DISTRICT ENGINEER WITH FINAL PLAN CHECK AND INSPECTION FEE AND SEWER CONNECTION FEE.
4. SIGN AND RETURN EASEMENT FORM FROM DISTRICT, IF REQUIRED.
5. HAVE ORIGINAL IMPROVEMENT PLANS SIGNED.
6. SEND THREE COPIES OF IMPROVEMENT PLANS TO DISTRICT AND ONE COPY TO DISTRICT ENGINEER.
7. ACQUIRE ALL NECESSARY CONSTRUCTION PERMITS, AND SEND SHORING PLAN (APPROVED BY THE STATE) TO THE DISTRICT FOR ALL TRENCHES GREATER THAN 5 FEET IN DEPTH.
8. CALL DISTRICT (431-2223) 48 HOURS PRIOR TO COMMENCING CONSTRUCTION.
9. CALL DISTRICT (431-2223) 48 HOURS PRIOR TO ANY INSPECTION.
10. UPON FINAL INSPECTION AND COMPLIANCE WITH THESE SPECIFICATIONS, FACILITIES ACCEPTED BY DISTRICT.

#### NOTE

THIS CHECK LIST IS ONLY INTENDED TO SUMMARIZE KEY PROCEDURES DISCUSSED IN DETAIL WITHIN THE STANDARD SPECIFICATIONS. IT IS NOT A SUBSTITUTION FOR THE STANDARD SPECIFICATIONS, AND THE OWNER, DEVELOPER, OR CONTRACTOR IS REFERRED TO PART I OF THE SPECIFICATIONS FOR DETAILED INFORMATION ON THESE PROCEDURES.

LOS ALAMITOS COUNTY WATER DISTRICT  
ORANGE COUNTY, CALIFORNIA

## CHECK LIST FOR DEVELOPERS

REVISED 10 - 1980

1980

BOYLE ENGINEERING

S-10

